



WNG Damper Tools

- Damper Action Measuring Tool
- Belly rail shim for thick rail
- Belly rail shim for thin rail
- Underlever Center Height Gauge
- WNG Weighted Key Dip Block
- WNG Damper Hook - for spoon bending

Small Tools

- Right Angle Die Grinder
 - $\frac{1}{4}$ " or 6mm shaft disk pad
 - 120 grit 50mm or 2" Dia. Sanding disks
- Phillips screw driver - #2 tip
- 1" or 25mm wide sharp chisel
- Felt knife
- Pencil
- 6" Rule (preferably in metric)
- Straight edge - 48" or 1.2 meters long
- Bandsaw with 14" or 350mm throat capacity
- 4 Small C clamps

Small machinist's square
Machinist's scribe

Drill Bits

Countersink
2mm or 5/64" drill bit - jobbers length
4mm or 5/32" drill bit - jobbers length
4mm or 5/32" drill bit - aircraft length
5mm or 3/16" drill bit - jobbers length

Shop Tools

Air compressor
Band Saw
6" belt sander

Supplies

Titebond glue
WNG white glue
5 min epoxy
Travel paper
Assorted Front Rail Punchings
Razor blades



This procedure will feature the thick rail setup. The Damper Action Measuring Tool is setup for the thick rail by using the thick Belly Rail Shim.

To use the thin rail with spring flanges, use the thin shim. If you do not intend to use the spring flanges, use no shim.

Setup the damper action measuring tool with the thick shim.



Put the rod through the damper guide rail hole and rotate the main block around until the shim on the back of the block is pointed towards the belly rail.

The slide should be pointed forward.



Remove the felts from the back of the keys. Sand the felted area clean. You will need to mark the keyboard for several things; the length of key, the spoon pickup point and clearance for the spoon.

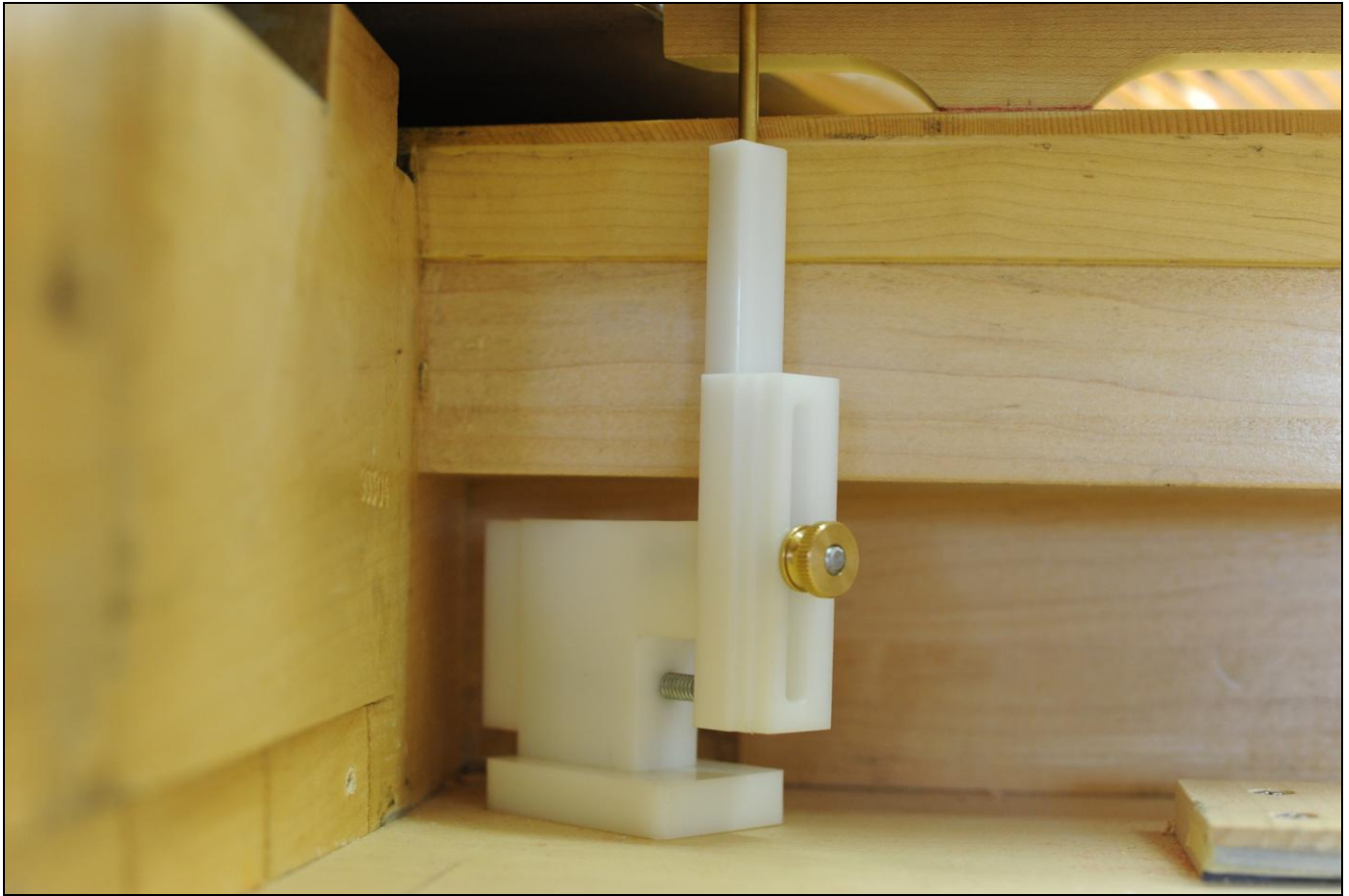

The slide in the front of the Damper Action Measuring Tool is for checking key length and how it interfaces with the WNG damper action.

The front of the slide and the notches on the bass side represent minimum key lengths required to work with the various spoons offered.

The notch on the treble side represents the maximum key length allowed to clear the tray.

The end of the slide indicates the minimum length for the key to work with the longest spoon.

The first notch back indicates the minimum length for the key to work with the standard or medium spoon.

The last notch indicates the minimum length for the key to work with the shortest spoon.



Raise the slide in the Damper Action Measuring Tool and place the keyboard in the piano. Position the keyboard with the keyblocks.

Make sure that the keyboard is correctly positioned.

Lower the slide onto the end of the key.

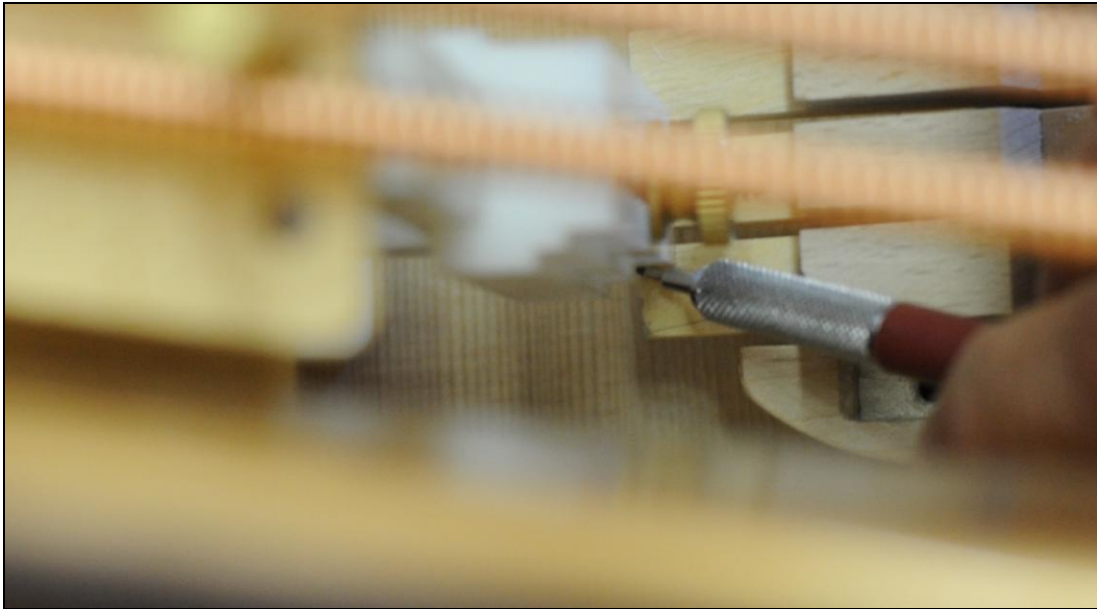

Make a mark on the key for the ideal length of the key for the spoon you selected. Do this measurement at both ends of the damper guide rail.



Mark the key 6mm (.236in) forward from the ideal key length mark. This is the spoon pickup point.

Mark the key 12mm (.472in) forward from the ideal key length mark. This is the spoon clearance required for reliable operation.

Place these marks on the first and last keys that lift dampers.



Transfer the ideal key length, spoon pickup point and required spoon clearance marks to the side of the first and last keys with dampers.

After the key end felt is installed, these marks will still be visible.

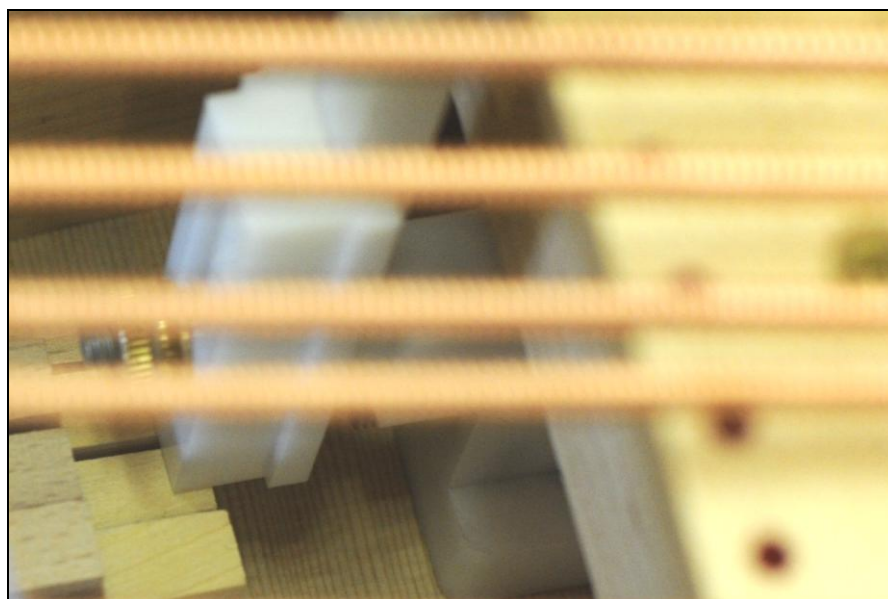

On the treble side of the slide you will see a single notch. The keys cannot come any further back in the piano than this notch. Longer keys will hit the sustain tray when played when either is operated.

Mark the key on the lowest and highest damper with this measurement if the key goes further back than this notch. If too long, you will need to shorten the keys to make them work with the new WNG back action.

Keyboard Preparation

Previously marks were placed on the key for ideal key length, the spoon pickup point, spoon clearance and, perhaps, for shortening the keys.

Most of the time, these measurements will demonstrate that the keyboard will work properly with the WNG Damper Action. In this circumstance, no modification of the keyboard will be required.

If, however, these measurements indicate that modifications are needed, they should be done now. The tasks are relatively easy.



There are several possibilities here.

If the key is longer than required but shorter than the maximum length allowed, no modification of the keyboard is required and you can skip this step.

If the key is longer than the maximum allowed length of the key it must be trimmed. There is no choice. The key will hit the sustain tray if you do not trim the keys. This will render the piano inoperable.

If you must trim the key, WNG suggests that you trim to the ideal length as opposed to the maximum allowed length.

Whatever modification you choose, draw a line down the keyboard where you wish to cut.

Use a block of wood to support the back of the keys on the keyframe. Raise the keys so that the balance hole is about 3mm or 1/8" above the balance rail and the front of the key is down on the front rail punching.

On the band saw, trim the key ends. If the keys are longer than the keyframe you will be able to do this without removing the keys from the keyframe.

If the keyframe comes further out than the keyboard you will need to remove the keys and shorten them one at a time on the band saw.

You only need to modify the keys that have dampers. You can cut all if you prefer but it is not necessary.



Bandsawing keys, particularly one at a time, can leave them uneven and rough.

Use a sanding block with 80 grit sandpaper to sand the keys so they are even across the back of the keys. Also, round the bottom edge with the sanding block and if needed use a piece of sandpaper to remove any splinters from the edges.

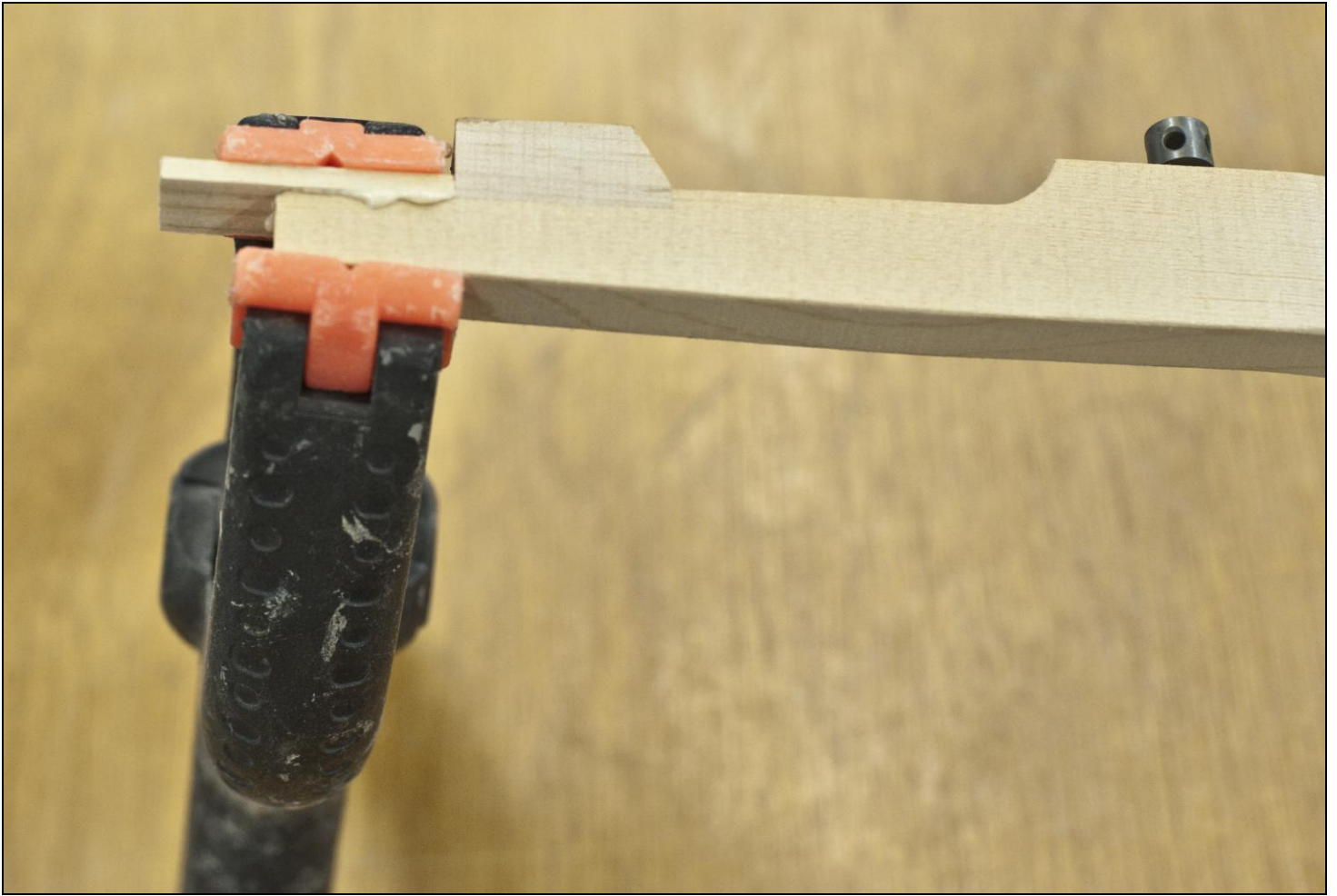

However unlikely, it is possible the keys are too short to reach the longest spoons offered by WNG. To solve this problem glue key extenders into the area where the key end felt was glued.

The key extender is about 3mm or (.118in) thick and is made from vertical grain pine or spruce. You can extend the key by about 10mm (about .3937in).

Glue the key extenders into the keys with Titebond glue. Trim the sides flush to the keys.

Re-mark the ideal key length, spoon pickup line, spoon clearance and maximum key length. Make sure that the marks on the sides of the keys are present and readable.

Cut the key extenders to the ideal length.

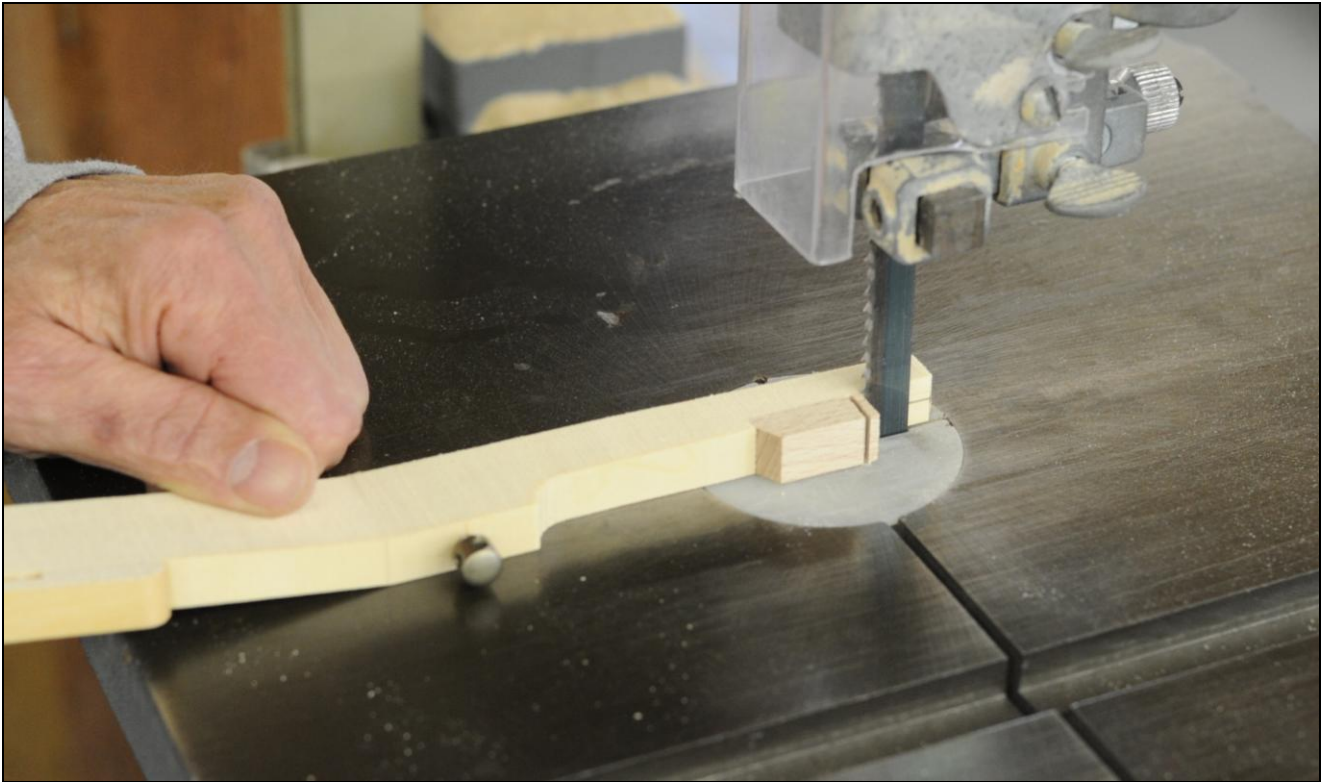

It is not out of the question that there will not be enough room in front of the spoon pickup line. If this is the case you will need to make more.

Measure towards the front of the keyboard 6mm or about $\frac{1}{4}$ " from the spoon pickup line to mark the clearance needed for the spoon sliding back and forth on the key during operation. Draw a line on the key for this dimension.

If there is more than 6mm (.236in) room forward from the spoon pickup line you need do nothing.

If there is less than 6mm (.236in) room you must cut the back check blocks to create this room. Necessarily you will have drawn your line on the back check block itself if this is the case.

Take the keys out of the keyframe and cut the back check block one at a time making more room to glue on key end felt on the back of the key.

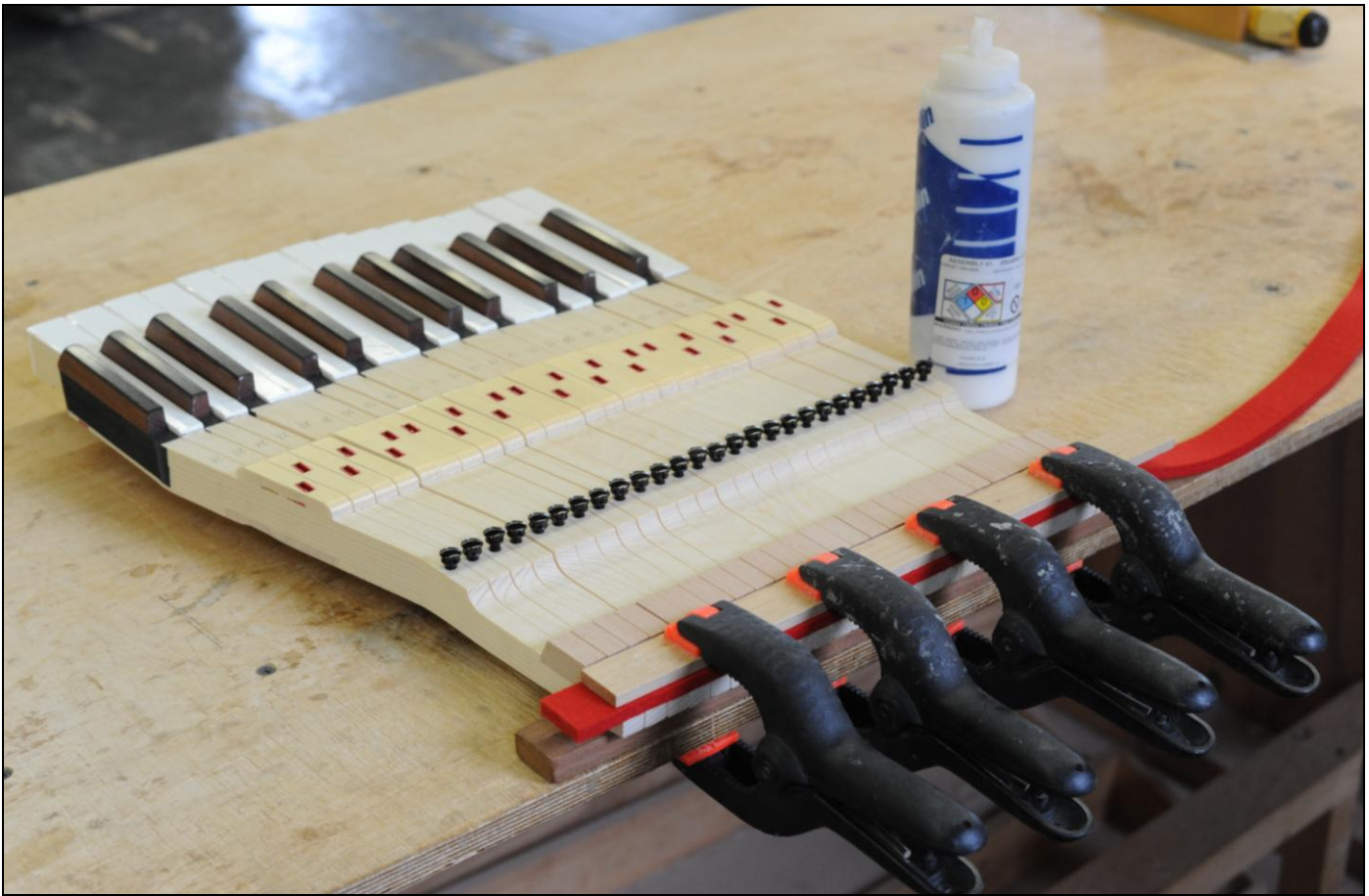

Glue key end felt on the keys.

Remove about a dozen keys at a time and place on a bench. Place a piece of $\frac{1}{4}$ " or 6mm plywood under the group of keys. Have another piece the same size at the ready.

Cut a strip of key end felt so that it is larger than the gluing area.

Brush on WNG Piano Makers Glue onto the group of keys where the key end felt goes.

Place the felt on top of the glue. Put a thin piece of plywood on top of the felt. Use spring clamps to clamp the key end felt between the two pieces of plywood.

Do this on all the keys that have dampers.

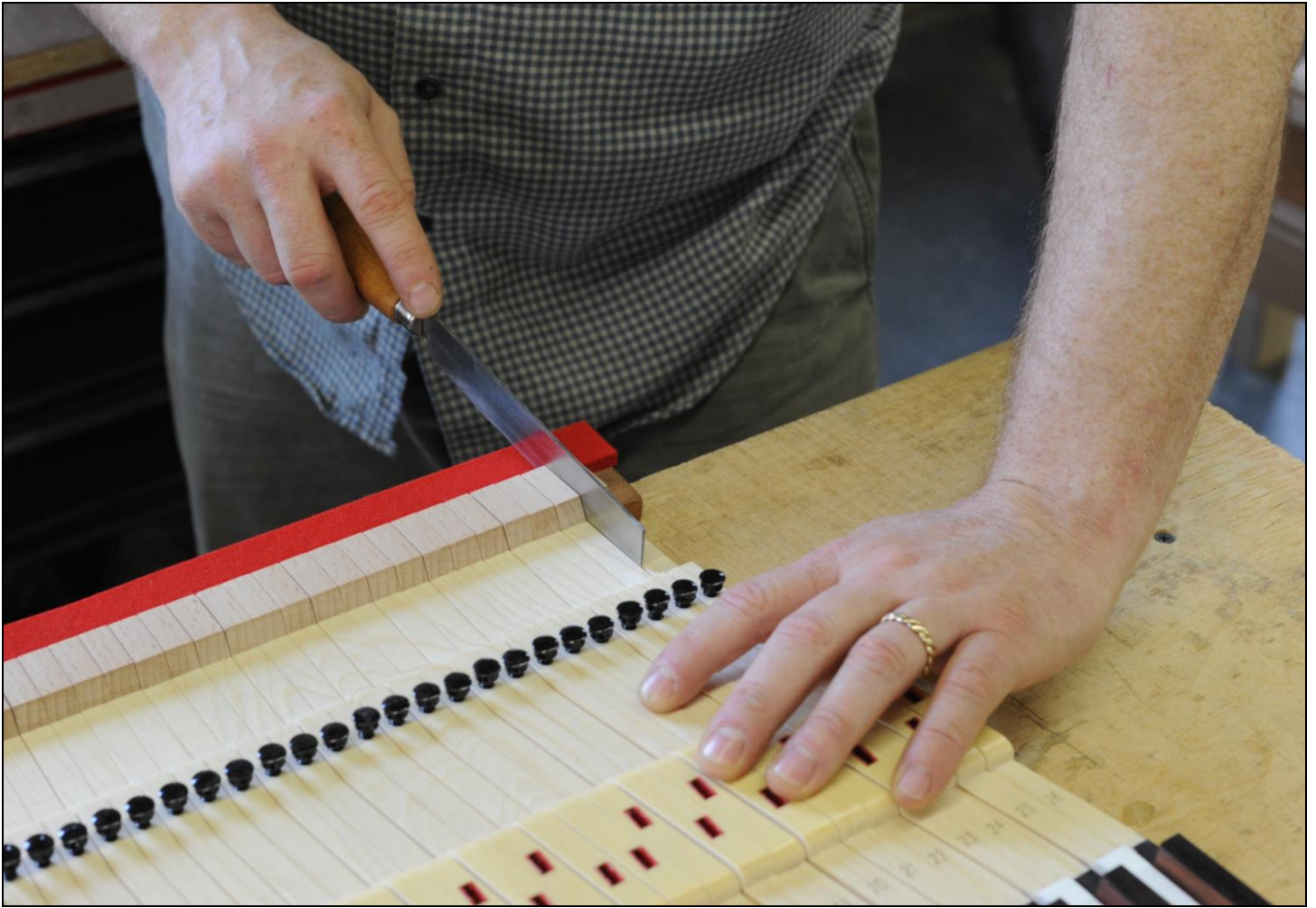

When the glue is dry remove the clamps and pieces of plywood from the key end felt.

Place the felt down on a piece of wood to use as a cutting board.

Trim the felt from the ends of the keys first so that it is flush.

Trim the felt from the sides of the keys. Work a knife between the keys to trim between the keys.



Now the keyboard is prepared for the damper action.

Damper Action Preparation

You have selected and ordered a back action. Now it is time to install this damper action into the piano.

Any new action needs traveling. At WNG we rough travel the action. You, however, need to finish the traveling.

As with a repetition, traveling occurs in two axis. At WNG we use the terms "Swing" and "Tilt" to refer to each axis.

Traveling is important because you will greatly complicate the damper wire bending if the under levers are not rotating in consistent arcs.

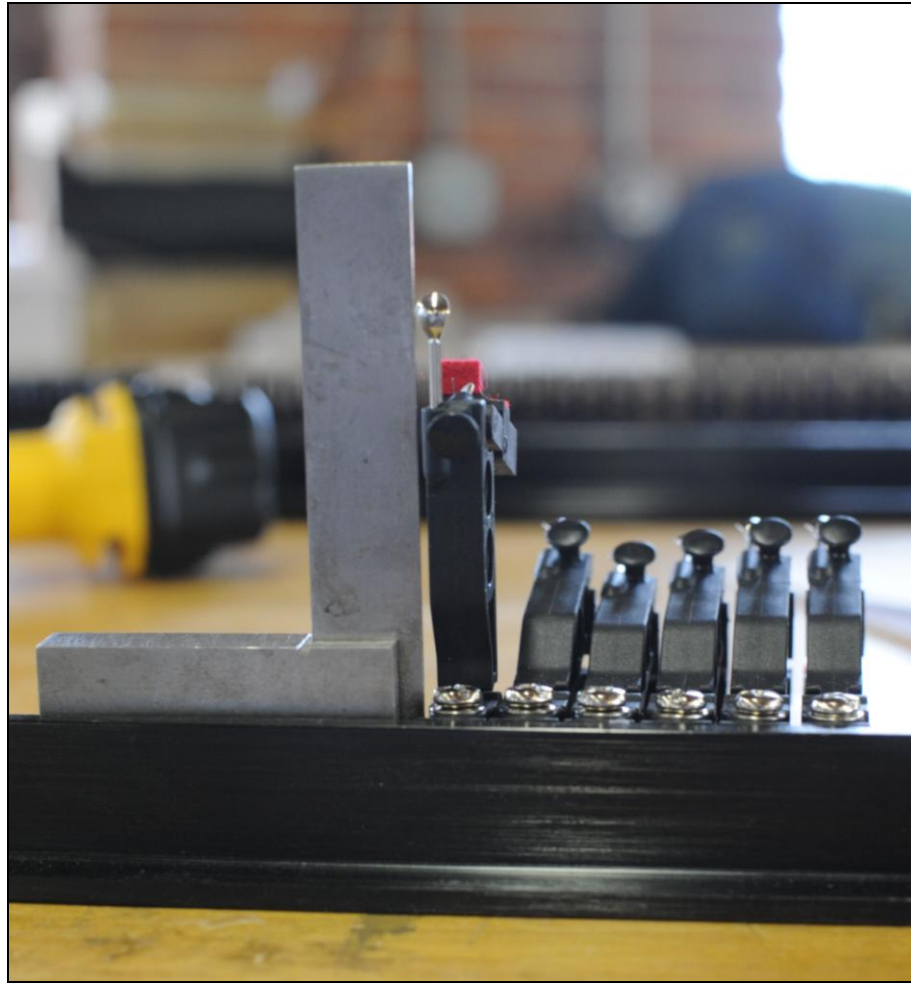

Swing refers to whether or not the under lever is perpendicular to the flange rail.

To travel for "Swing", place paper between the back of the flange and the rail. The paper will "Swing" the under lever to one side or the other. Do this until the under lever is perpendicular to the flange rail.

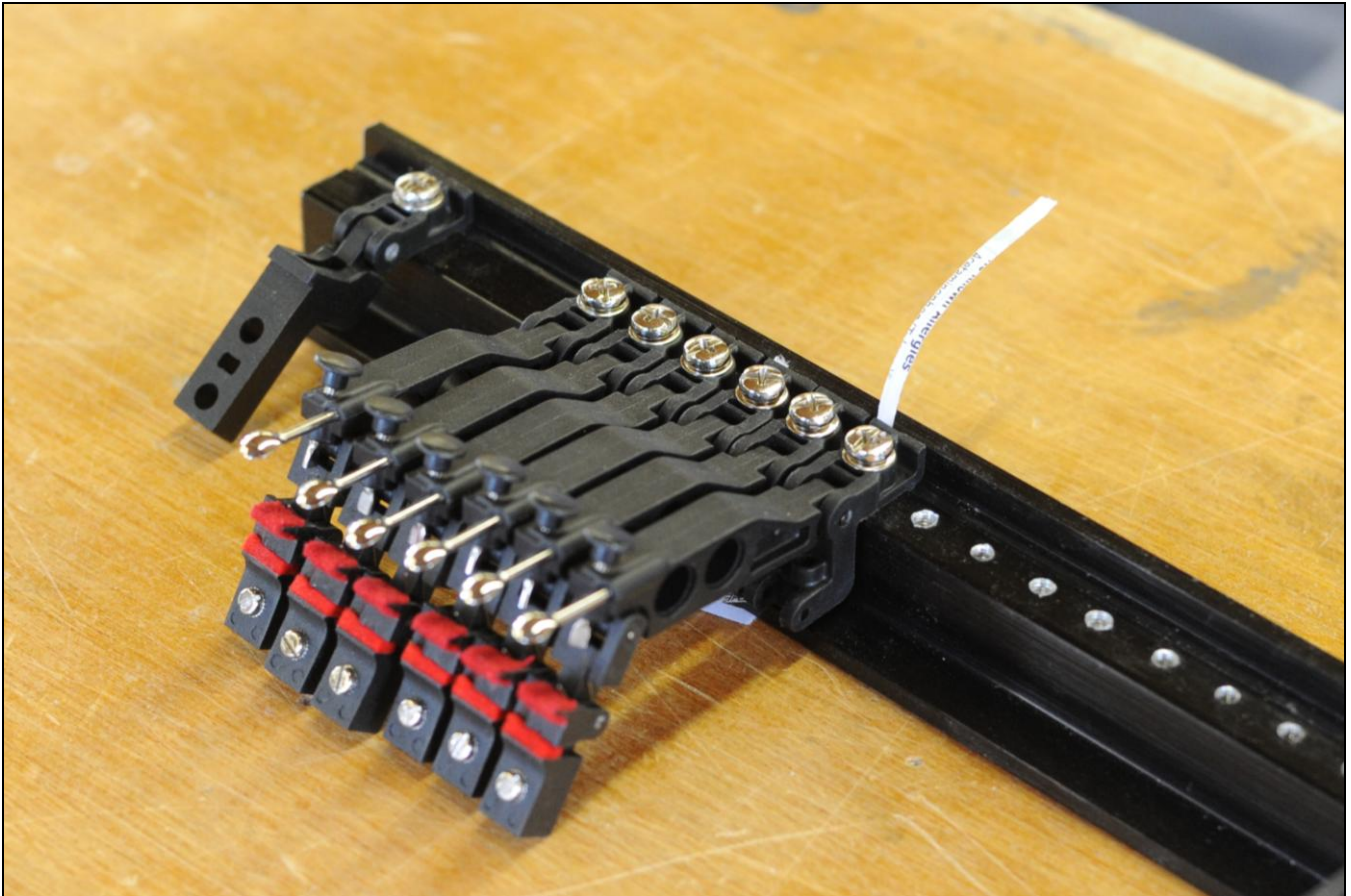

Tilt refers to whether or not the under lever rotates in a genuinely vertical arc.

Tilt is tested by using a square. Place a square next to the spoon and rotate the underlever. If tilt is correct the spoon will maintain the same clearance to the square throughout its normal range of motion.

Tilt is corrected by placing paper strips under one side or the other of the flange at the bottom of the rail.



Once the damper action is traveled, it is necessary to bend the spoons to match the keys. Because it is easy, at this point in the process we will bend the spoons to the edge of the keys. This is not how it will be mounted in the piano.

On most pianos, the soft pedal shifts the action towards the treble. A few shift to the bass. You will need to space the spoons to side of the key the action shifts towards. That is, on a treble shift piano, space to the treble side of the keys. On a bass shift piano, space to the bass side of the keys.

Place the keyboard, with the key ends felted, on a flat workbench. Place the damper action on the bench behind the keyboard. Locate the spoons on the key end felt so the center of the spoon is on the spoon pickup mark at both ends.

Align the damper action side to side so the edge as many spoons as possible are as close to the appropriate edge of the keys as possible. Once located, clamp the keyboard and the damper action so it cannot move during spoon bending.

Using a simple wire bender, bend each spoon side to side until the edge of the spoon is on the appropriate edge of the key.

Now you have aligned the spoons to the keys. Notice that you have just easily done something that is quite difficult to do with the traditional wooden damper action.

Set the Damper Action to the Correct Height

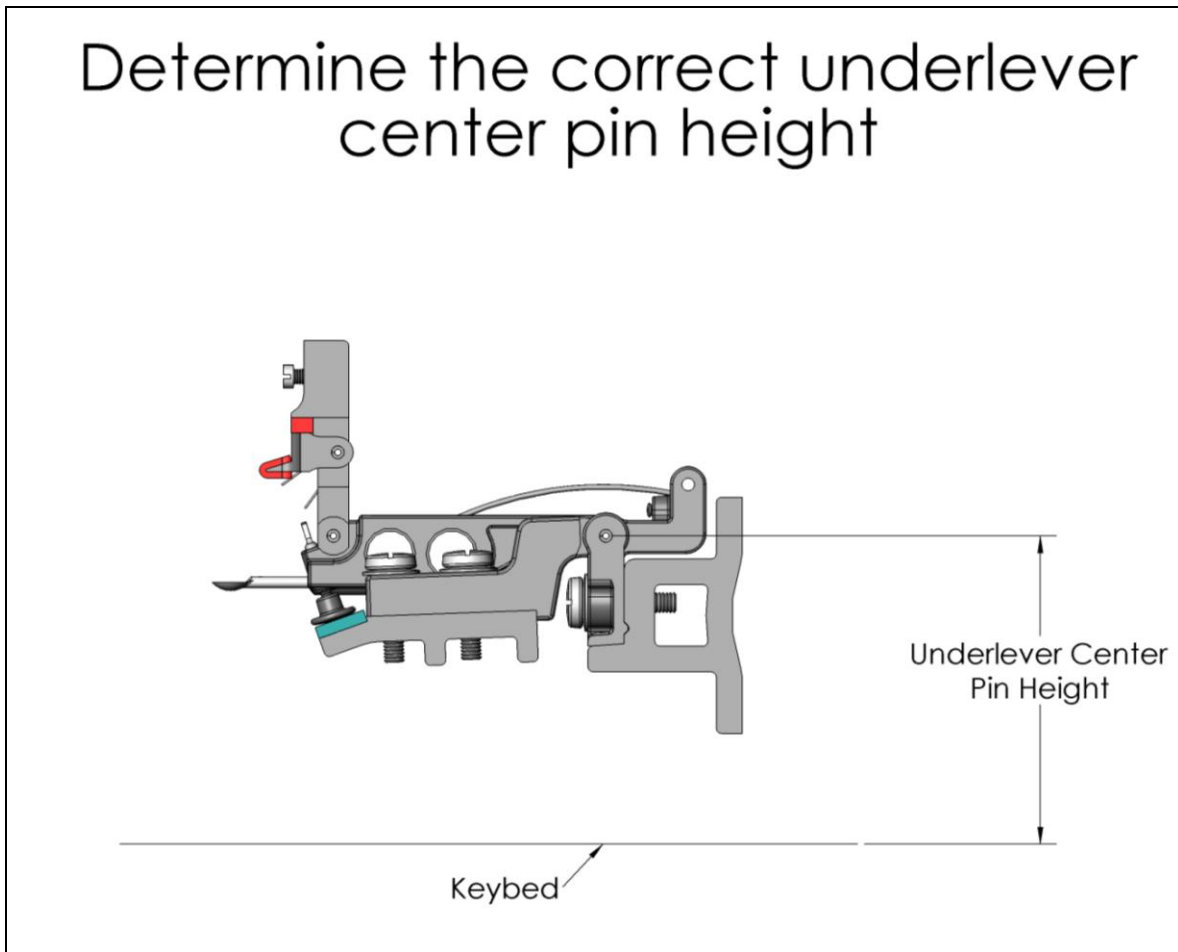

Underlever center height is the vertical distance from the keybed to the underlever center pin.

Because the WNG damper parts are a new design, the new damper parts are likely quite different than the old parts. Consequently the old underlever center height is probably not correct for the WNG damper action.

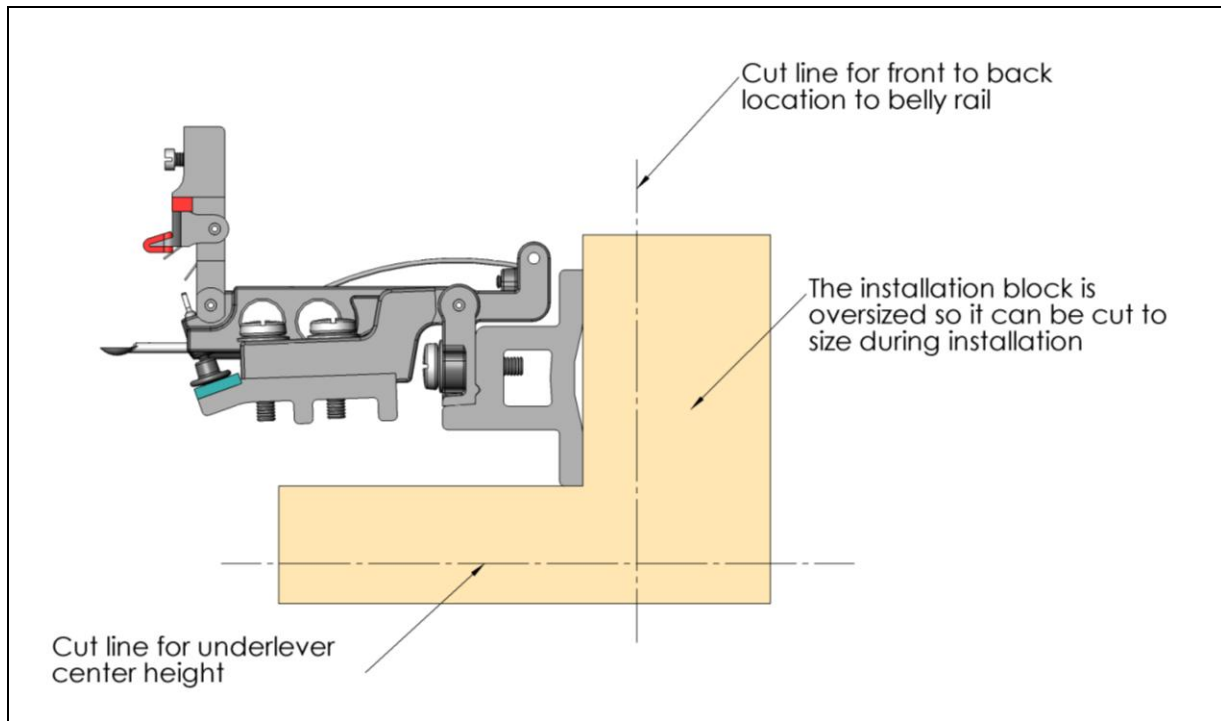

WNG had designed installation blocks to make the task of positioning the damper action easy. When cut to size, the installation blocks correctly position the damper action in your piano.

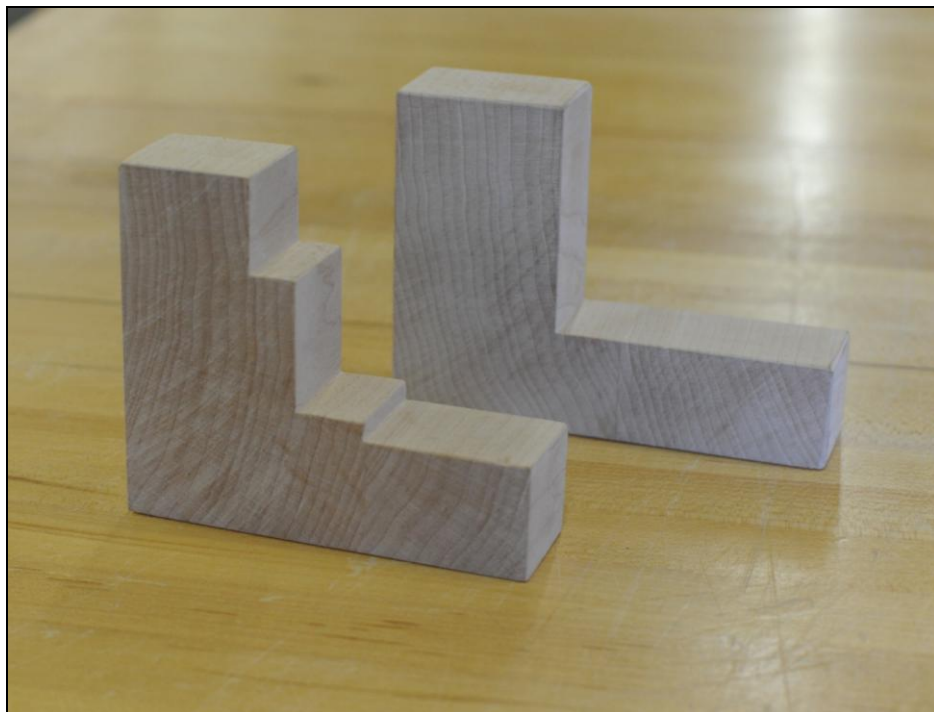

There are two types of blocks.

On the left is the block for the thin rail.

On the right is the block for the thick rail.

The kit you order will include the correct blocks required based upon the damper flange rail you order.

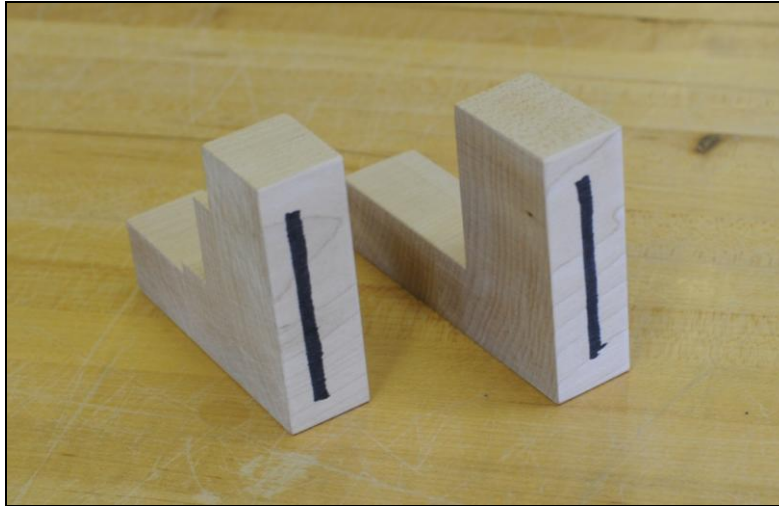

To avoid confusion, the sides of the blocks are color coded.

The side of the installation block that has the black mark goes against the belly rail.

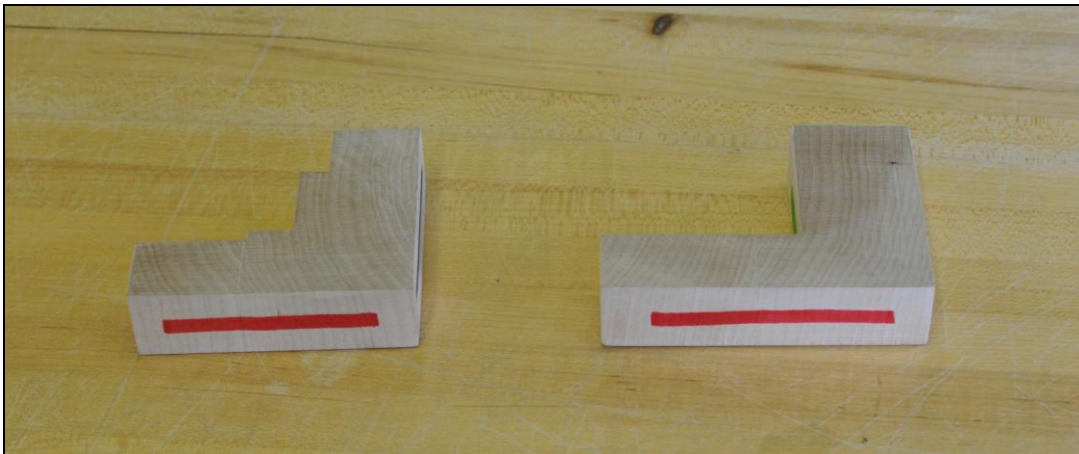

The side of the installation block that has the red mark goes down against the keybed.

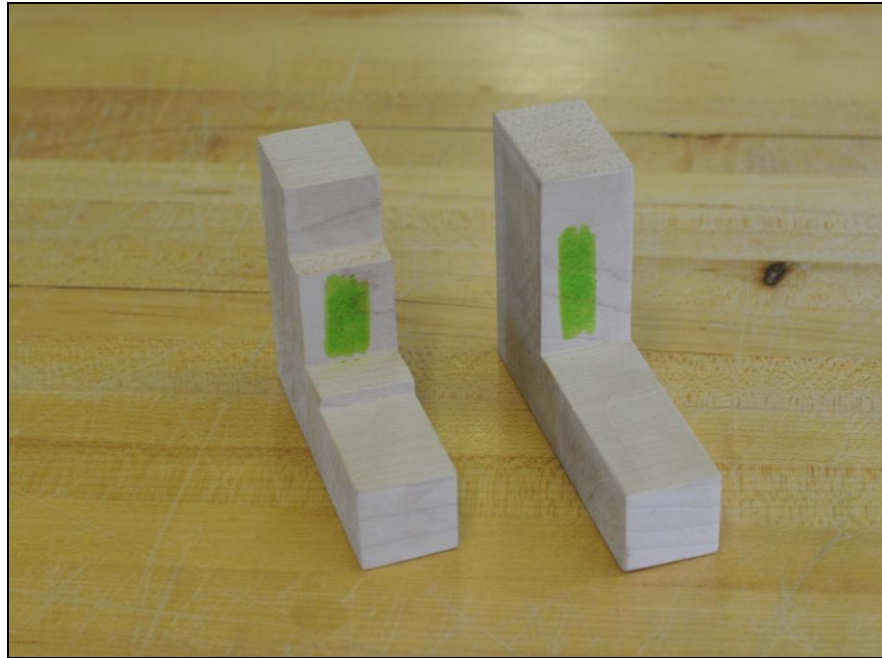

The side of the installation block that has the green mark is where you clamp the damper flange rail to the installation block.

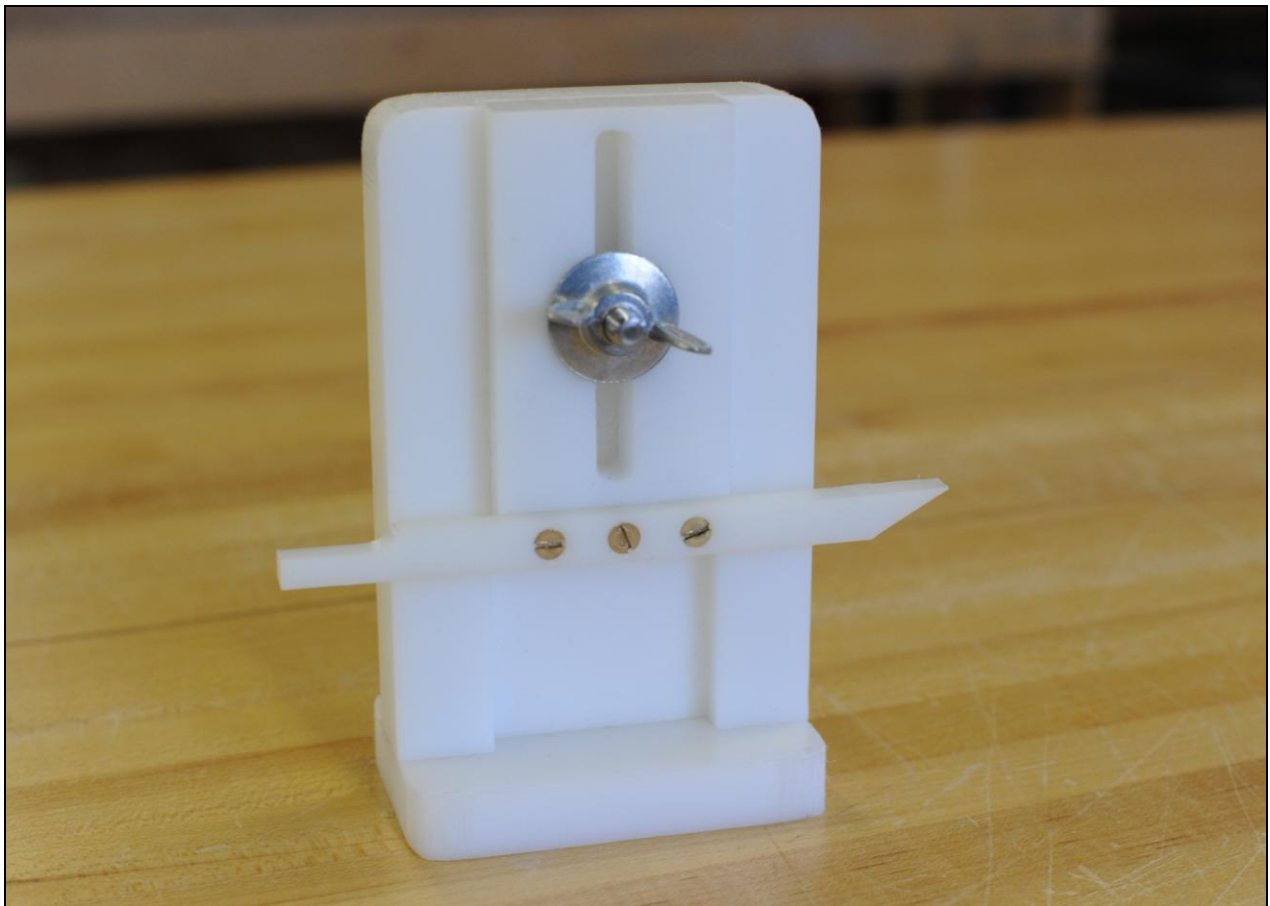

Without a doubt this method is the easiest way to arrive at a workable height for the under lever center height.

This tool is called the Under Lever Center Height Gauge.

On the left, the bottom of the cross piece rests on the damper pickup felt with the key at full depression.

On the right, the pointer indicates the correct height for the underlever center.



The keyboard, or at least the note in question, should be leveled and dipped. The key should be held in the down position with the weighted key dip block or a block of wood.

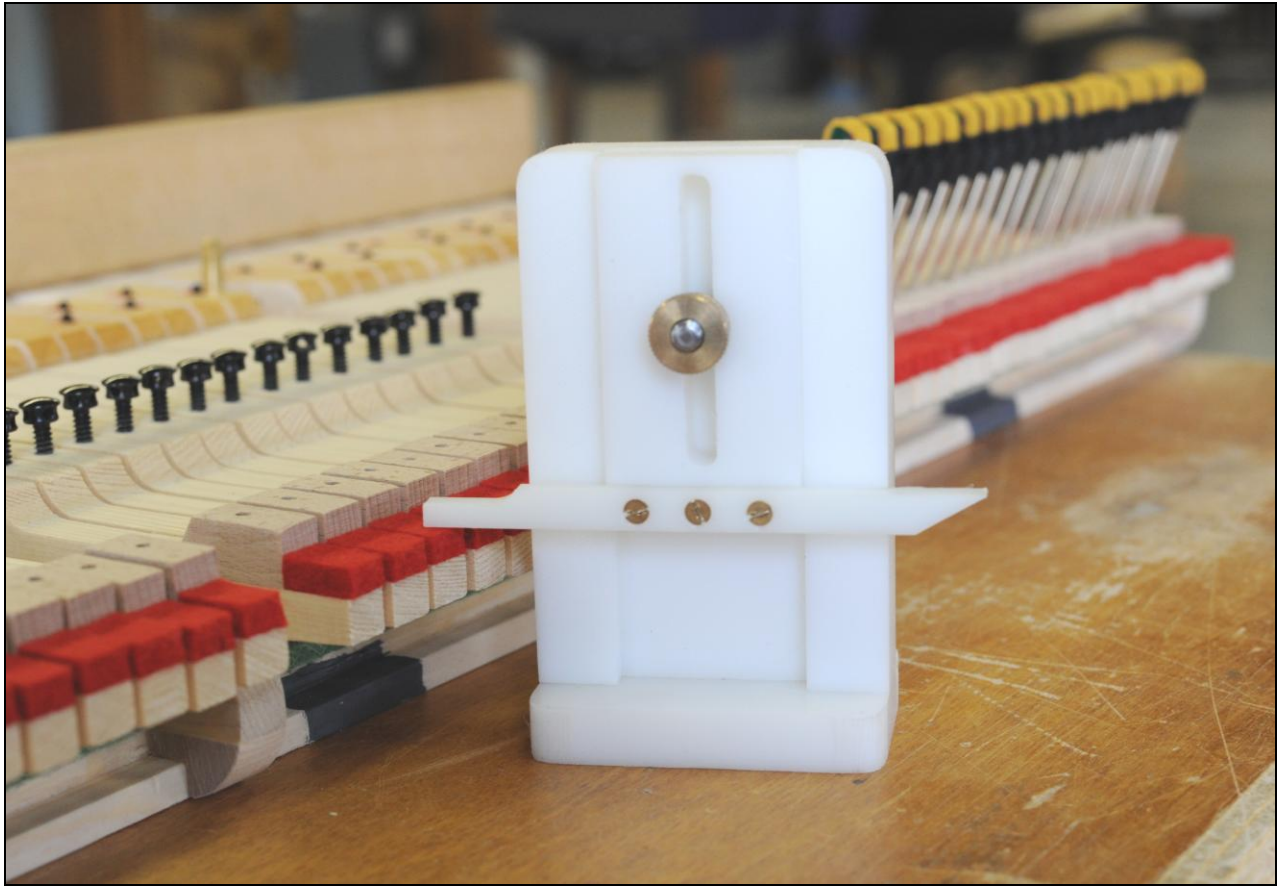

Place the WNG Under Lever Center Height Gauge on the bench behind the key you intend to measure.

Loosen the wing nut and lower the slide until the straight end sits lightly on the key end felt.

Tighten the wing nut

The pointer on the other end of the jig is the center height for the under lever.

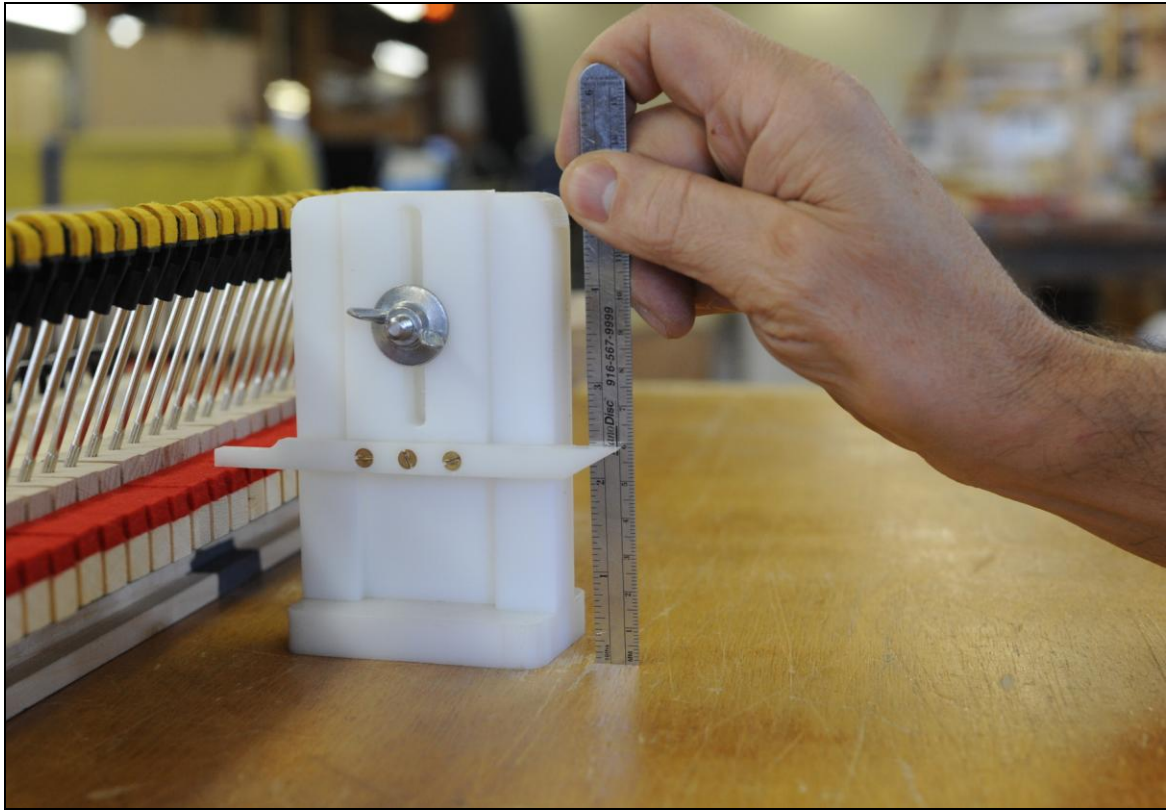

Move the WNG Under Lever Center Height Gauge to a clear place on the bench and measure the distance from the bench top to the pointer for the under lever center height.

This is the *Under Lever Center Height* dimension.

Write down this dimension. This is important!

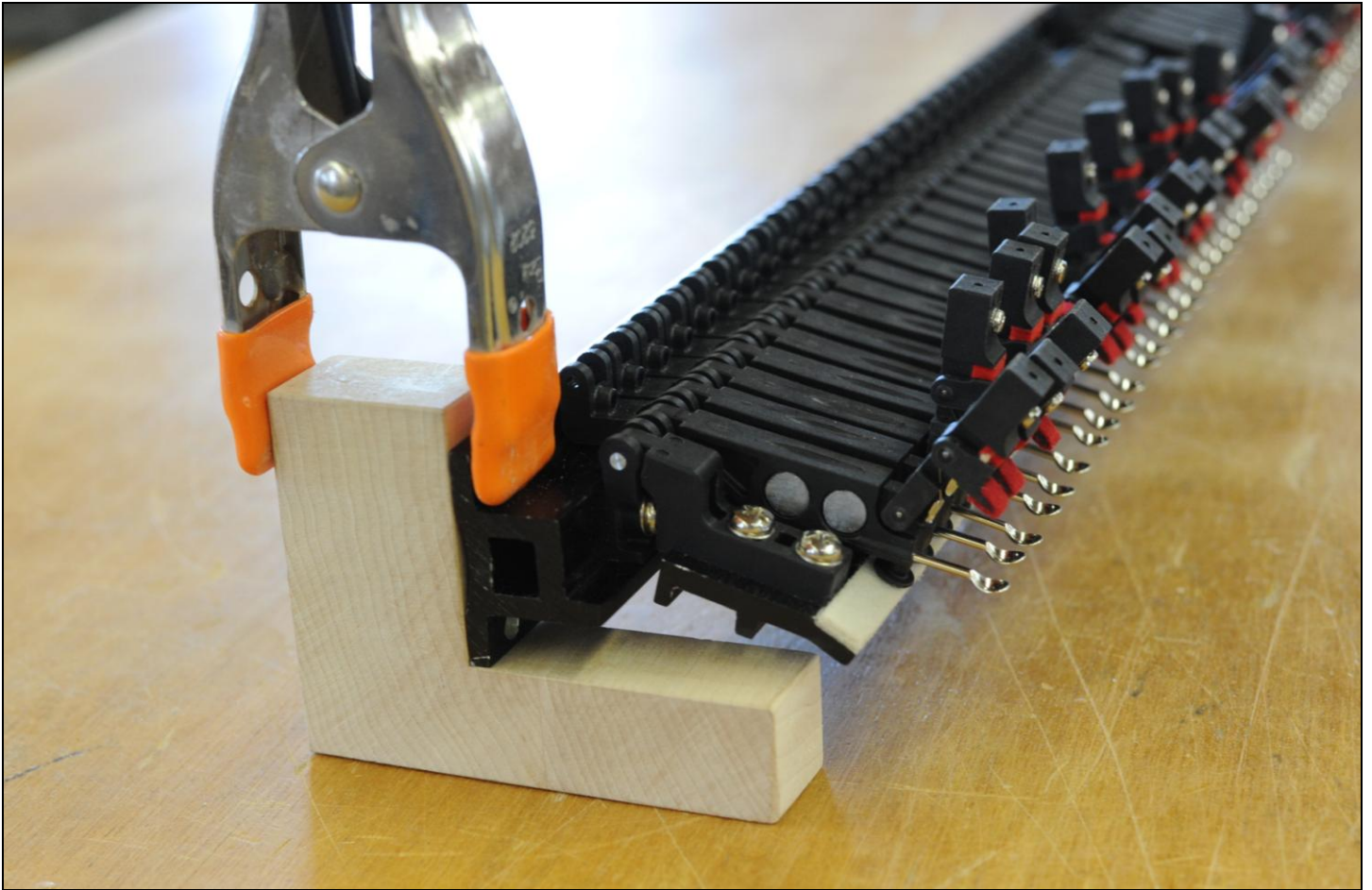

Clamp the installation blocks to the damper flange rail in the area marked green. Clamp one block at each end of the rail so that the rail is fully supported.

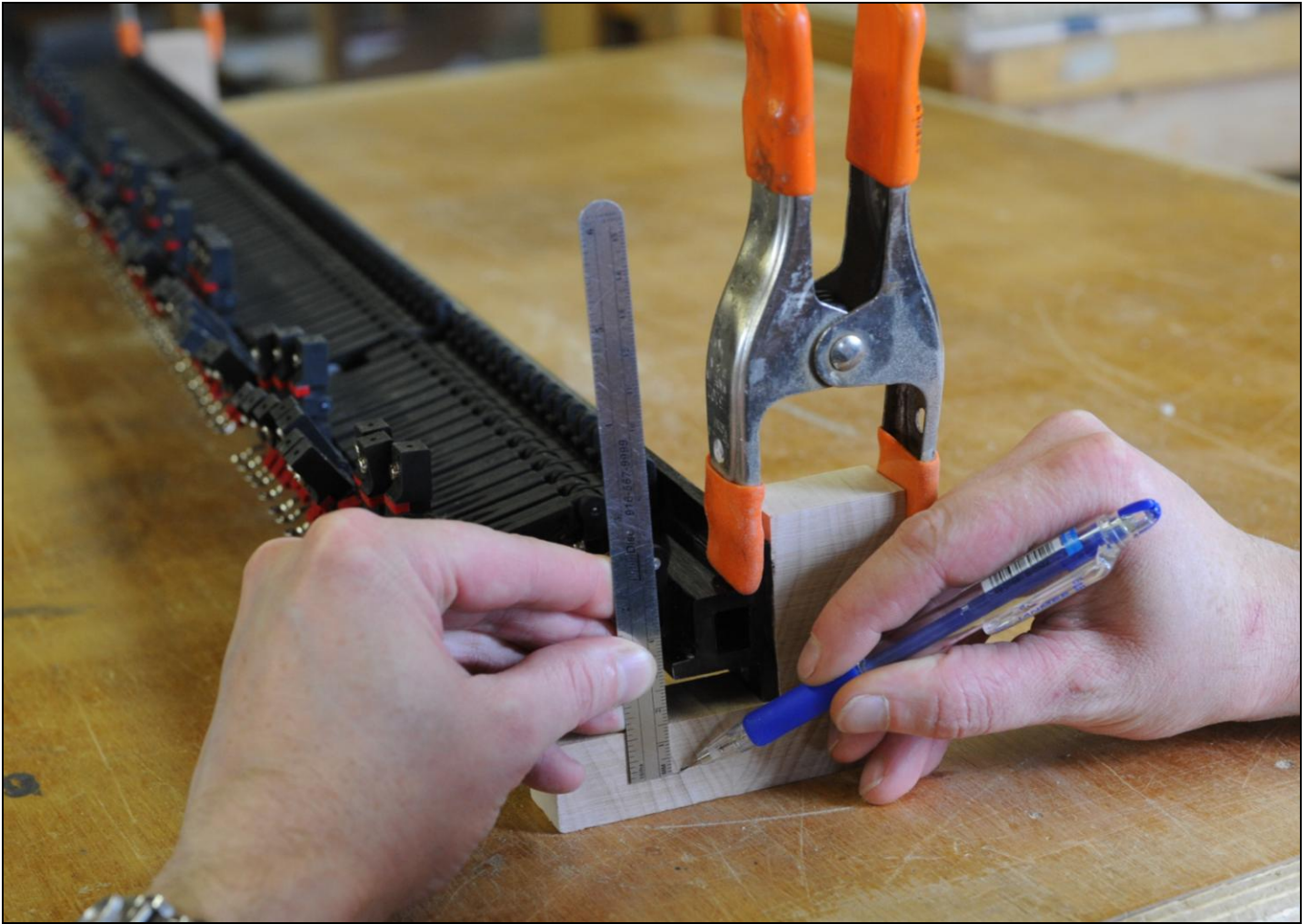

Earlier, you arrived at an underlever center height.

Measure down from the underlever center pin and mark on the block the Underlever Center Height you established with the gauge.

Because the center of the tray flange is on the same axis as the underlevers, the most sensible choice is to measure from the center of the tray flange.

Make a mark on the installation block at the correct Underlever Center Height.

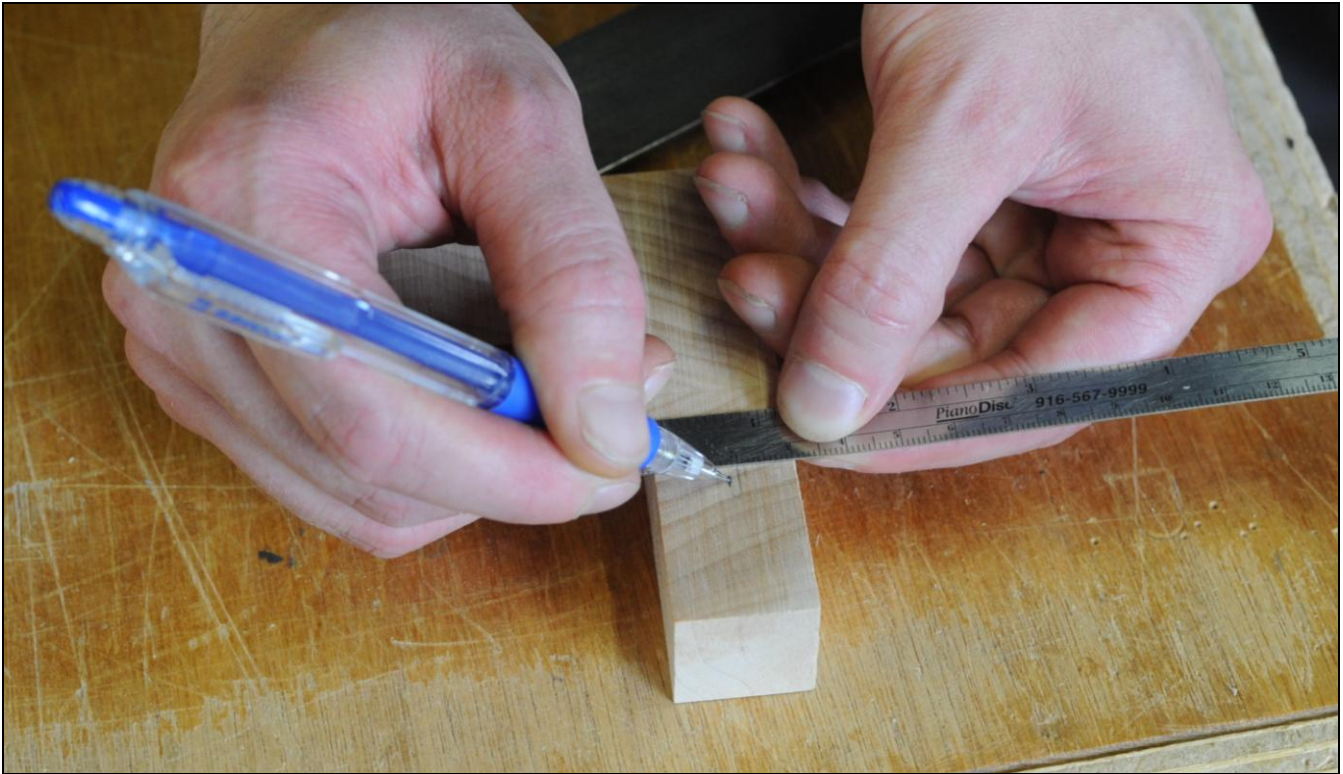

After the blocks are cut you will glue on bushing cloth so the final cut must take bushing cloth thickness into account.

Measure up from Under Lever Center Height dimension mark 1.2mm (.050in) to compensate for the thickness of bushing cloth.



Using a square from the belly rail edge, mark the cut line through the bushing cloth mark.



On a bandsaw, cut the installation blocks for height. Make sure that you do not cut too high on the block as it is easy to remove more material but considerably more difficult to add.

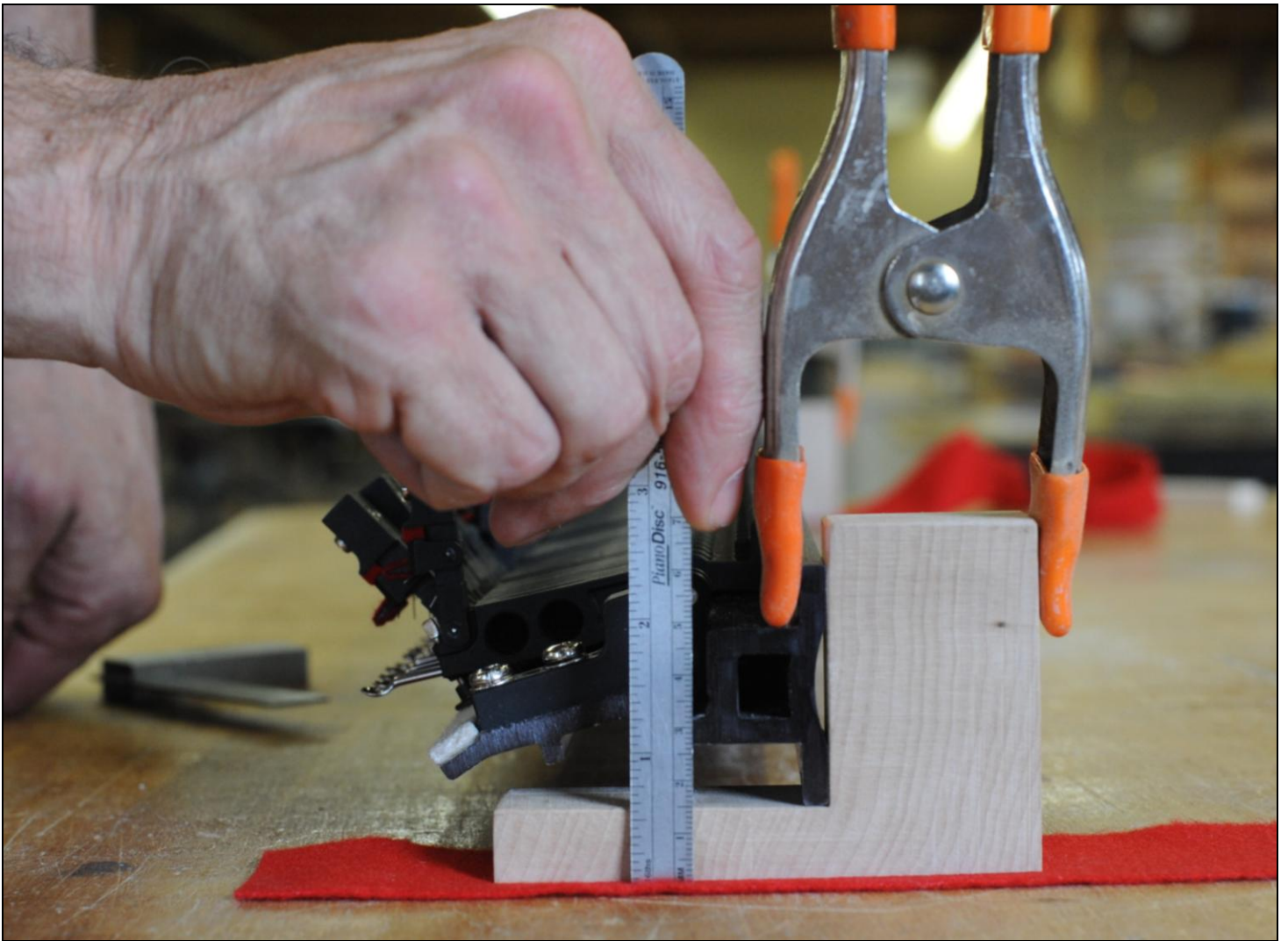

Re-clamp the installation blocks to the damper flange rail at each end as before.

Put a piece of bushing cloth between the installation block and the bench while it is supporting the damper flange rail.

Measure from the bench to the underlever center. A tolerance of $\pm .5\text{mm}$ or $1/64''$ is appropriate here. If the center is outside the tolerance then either add or remove material and check again.

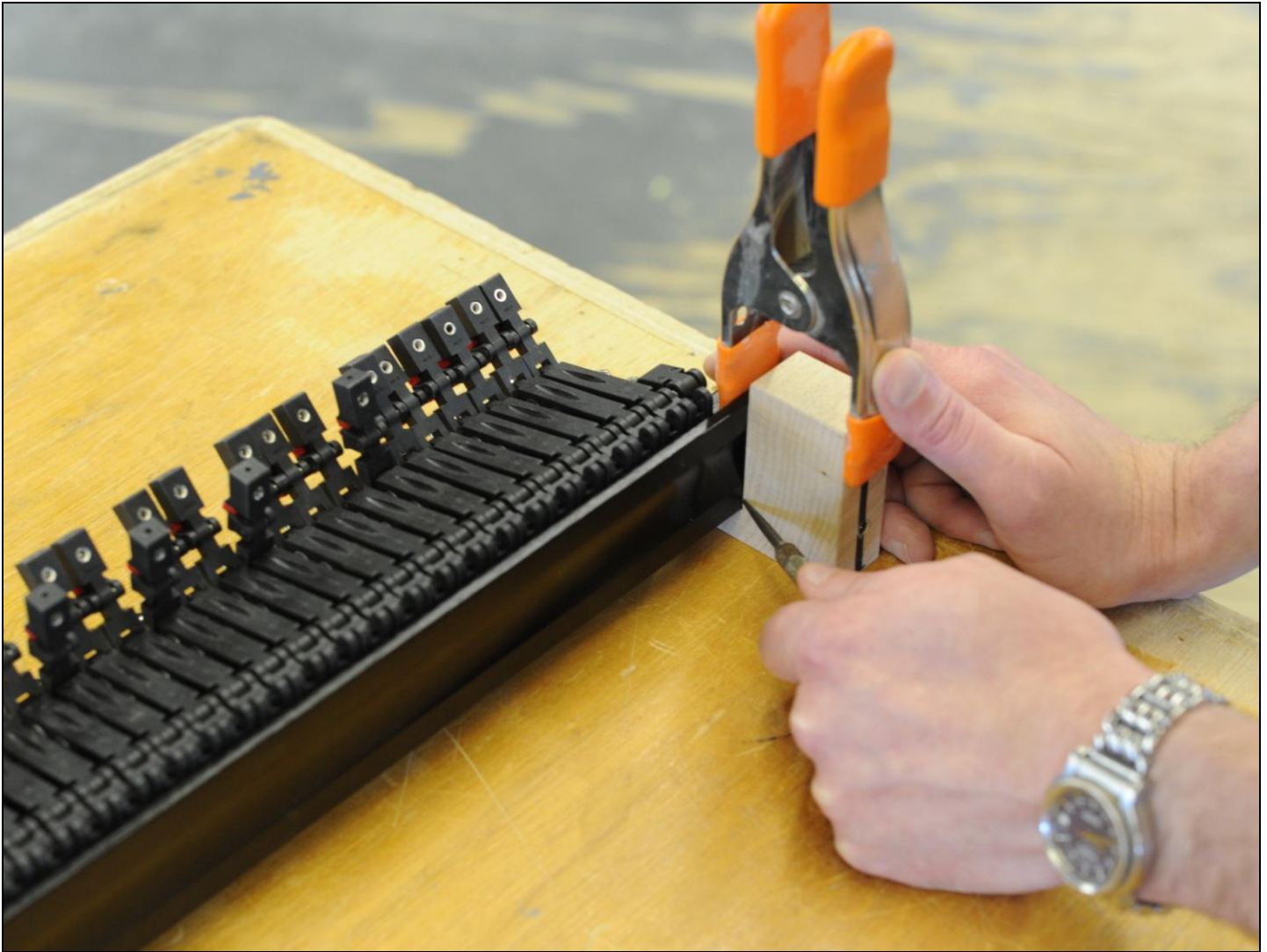

With a pointed scribe, scribe a line on the damper flange rail where it meets the installation blocks on the back of the damper flange rail.

On the thin damper flange rail you will need to do this on the center screw hole blocks as well. On both rails you will need to do this on the ends.

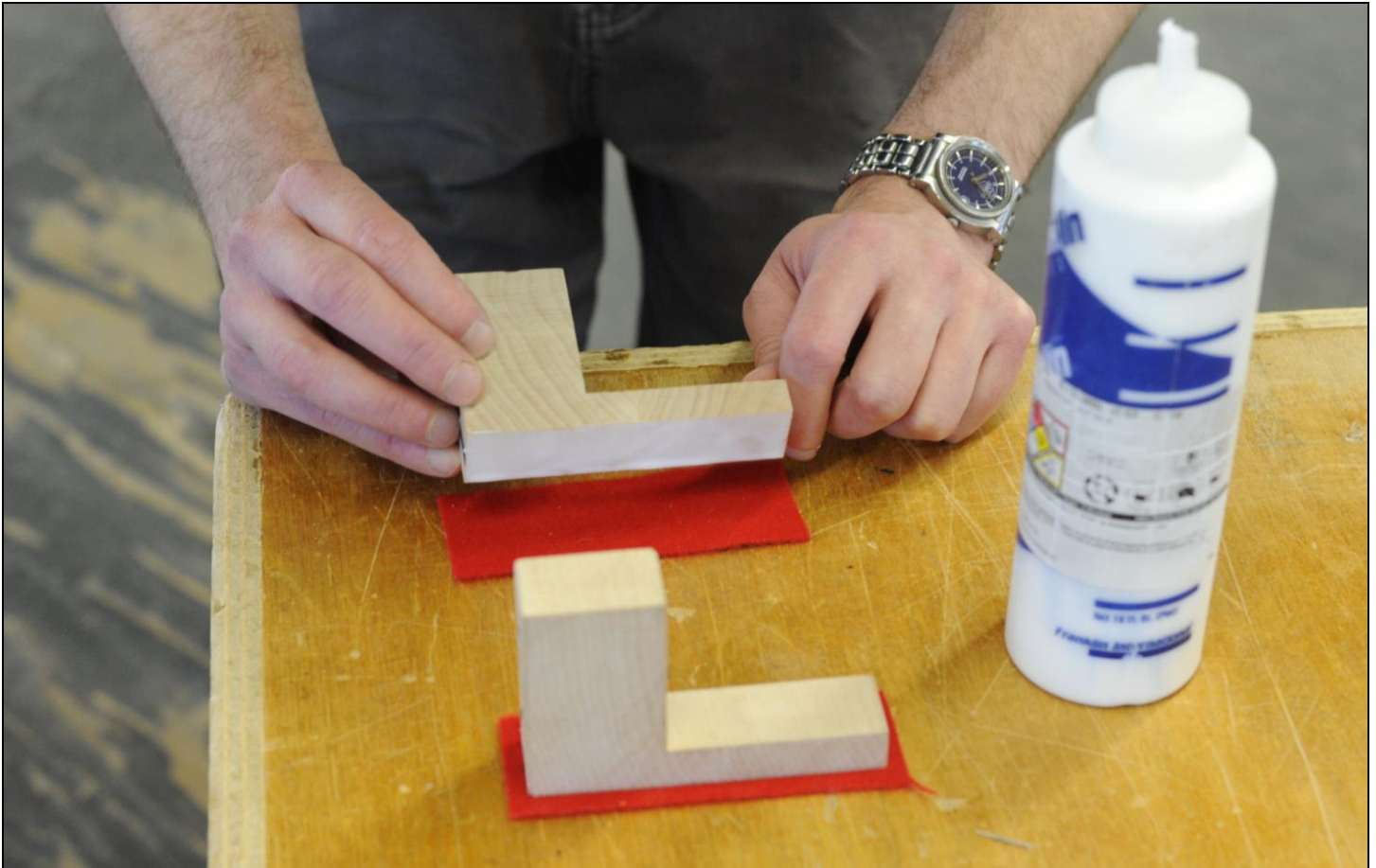

[Show gluing bushing material to the bottom of the installation blocks]

Glue bushing material that was supplied in the kit to the keybed side of the installation block. Use WNG Piano Makers Glue, Hot Hyde glue or any other glue you typically use to glue felt.



Use a die grinder with 120 grit disks. The disks are 2" or 50mm in diameter.

The anodization needs to be removed from the rail where they will be epoxied to the installation blocks. If you do not remove the black anodization the epoxy will not adhere.

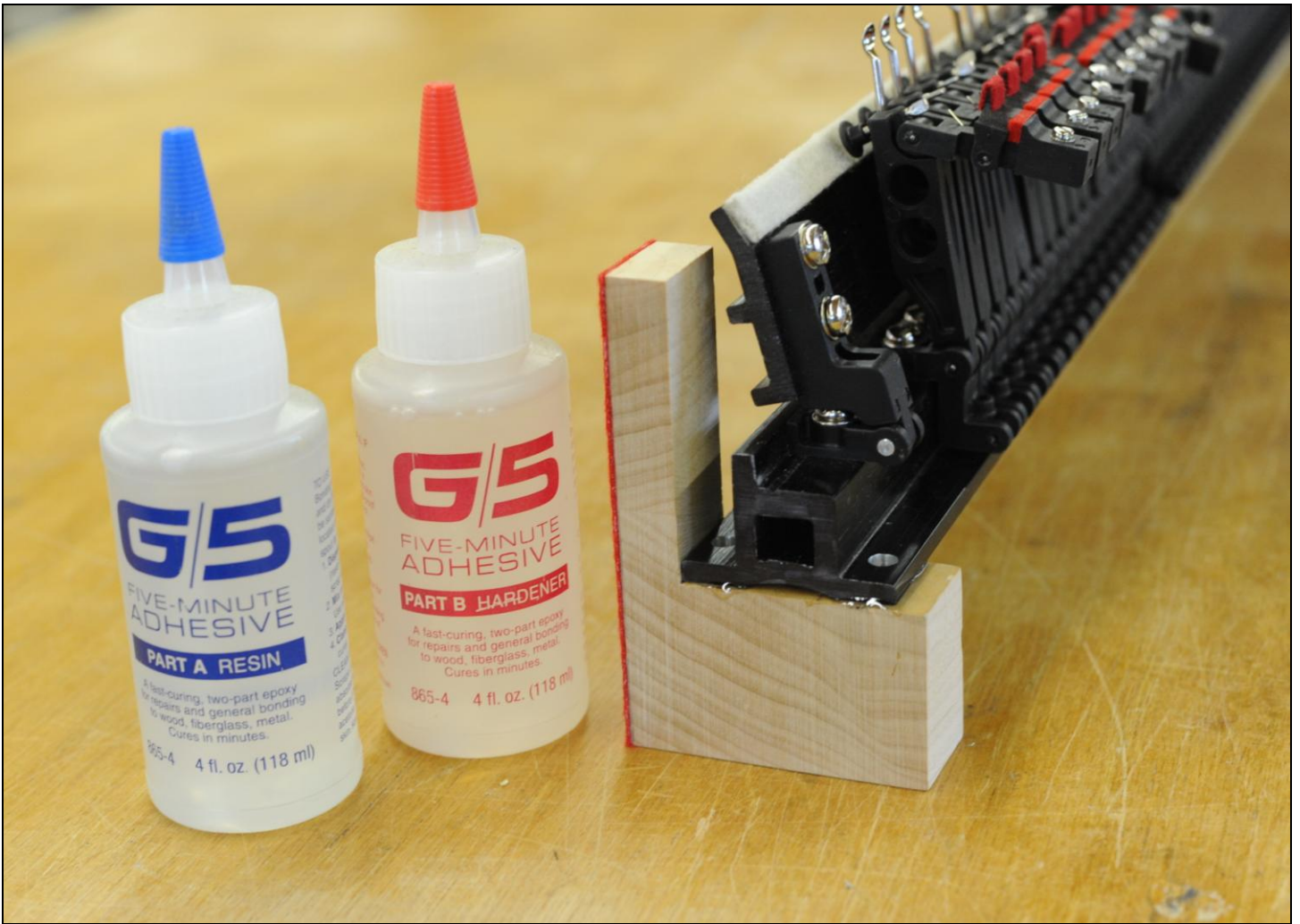

Apply epoxy to the installation blocks and position on the rail where you removed the anodization. Make sure that the screw hole in the block is centered over the corresponding screw hole in the rail.

Use 5 minute epoxy. Let set until the glue is firm.



Drill clearance holes through the installation blocks using the mounting holes in the rails as a guide. Use a long (aircraft length) 5.5mm (.217in) drill bit. The purpose of these holes is to ensure that later the screw will bite only in the belly rail.

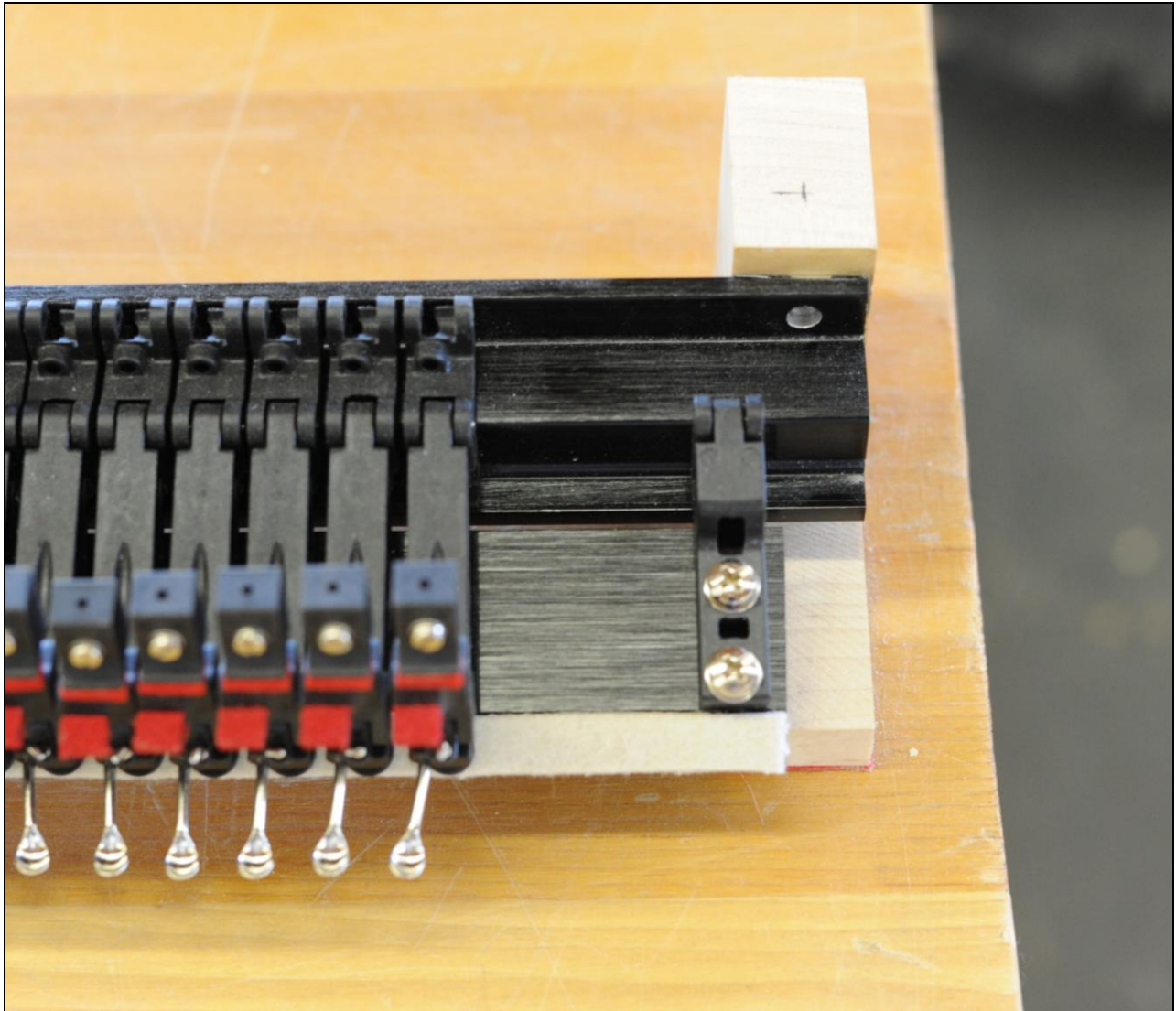

The damper action is now at the correct height however, another cut is required before it is ready to mount in the piano.

The blocks are oversize so at the moment the back side of the blocks need to be cut down so the damper action will be correctly positioned front to back in relation to the damper guide rail and the keys.

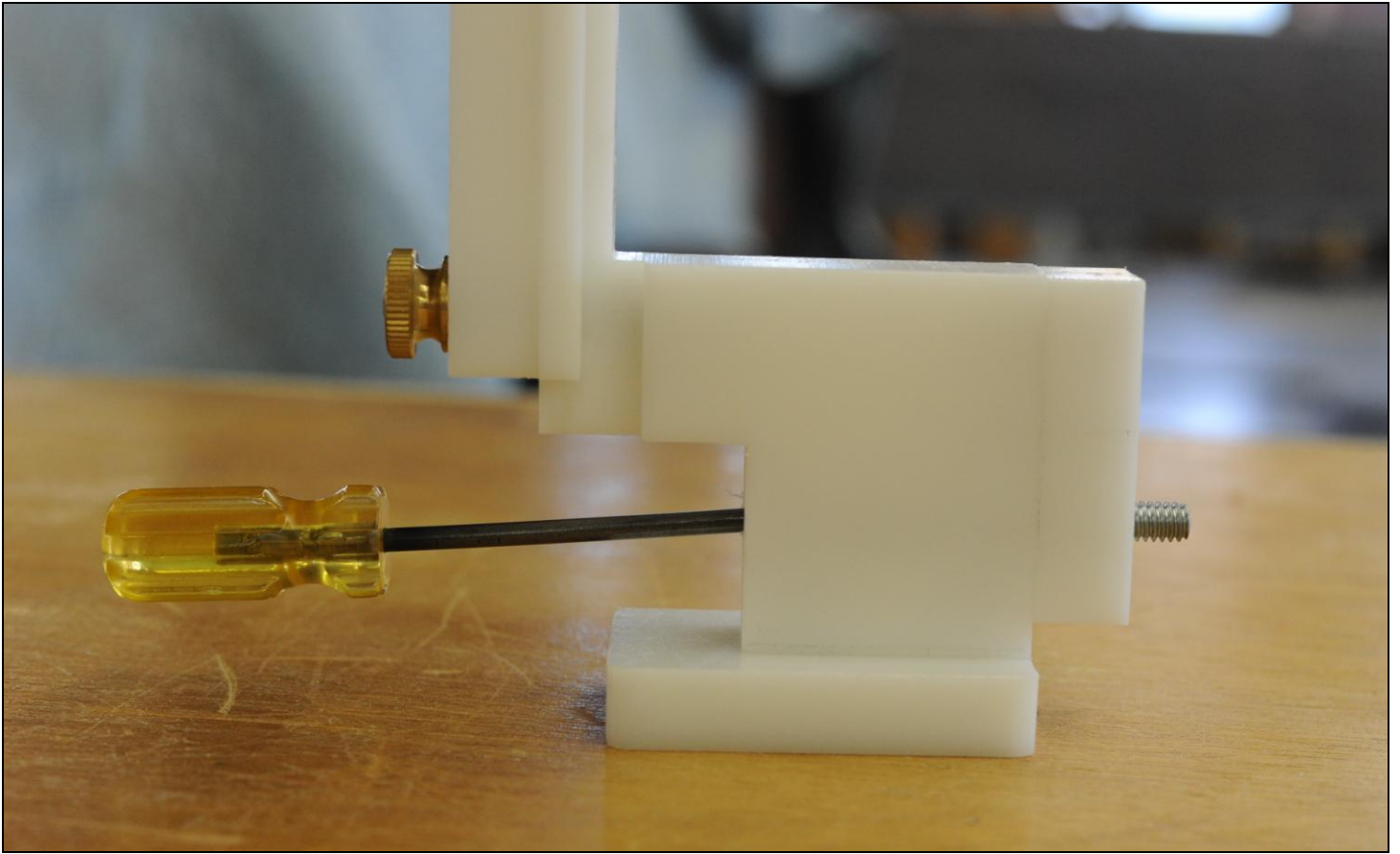

The WNG Damper Measuring Tool has the ability to measure the thickness required for the installation block. Notice the screw in the lower part of the tool.

Turn the screw back so it is flush with the back of the tool.

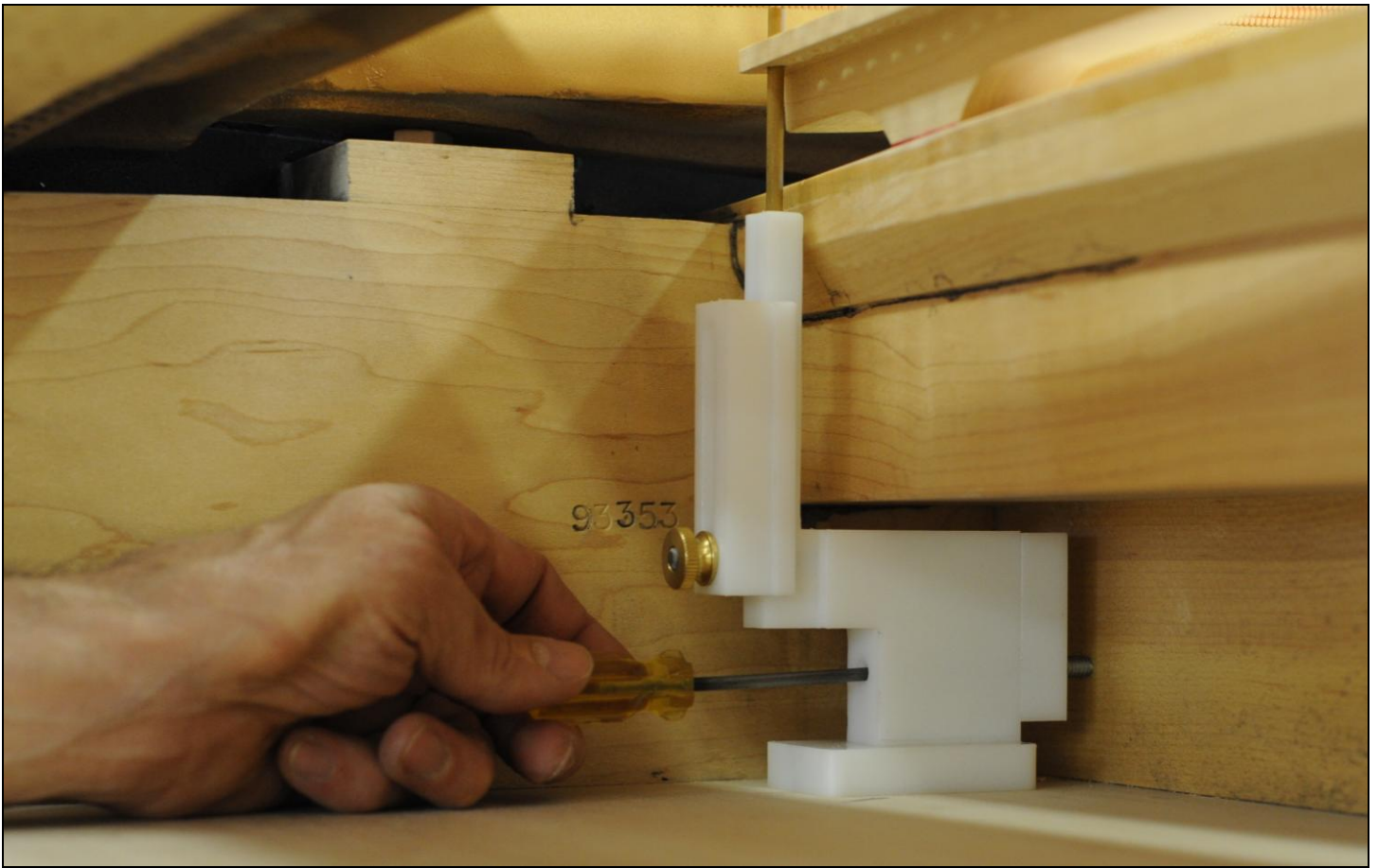

Place the tool in the piano in the lowest note with dampers, usually this would be note #1. Put the rod into the damper guide rail and rotate the tool until the back is pointed towards the belly rail.

With a slot screw driver, turn the threaded rod towards the belly rail until it just touches.

Remove the tool from the piano.

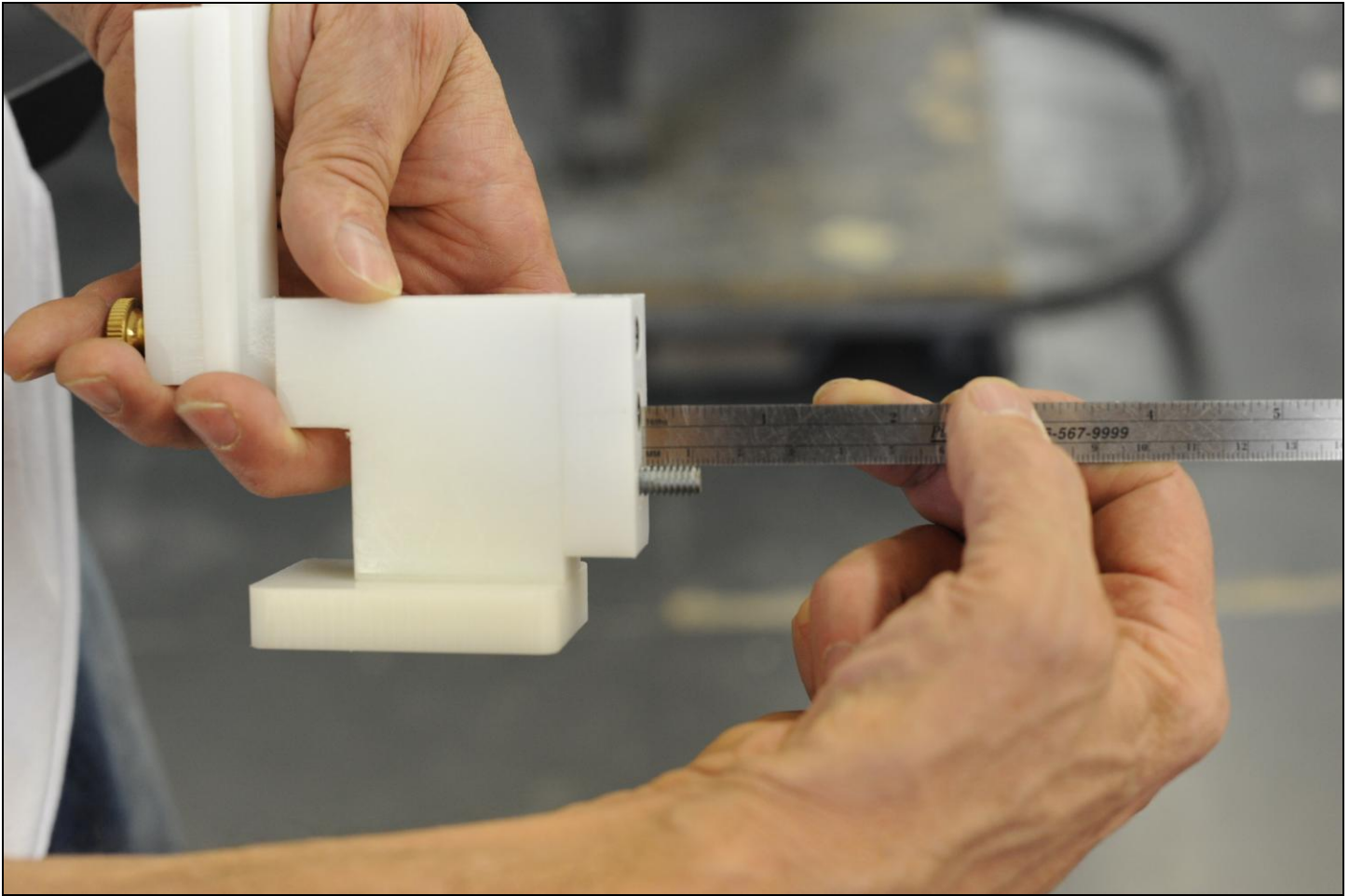

With a machinist's rule measure the amount that the threaded rod protrudes from the back of the tool. This measurement corresponds to the thickness of the installation block behind the rail.

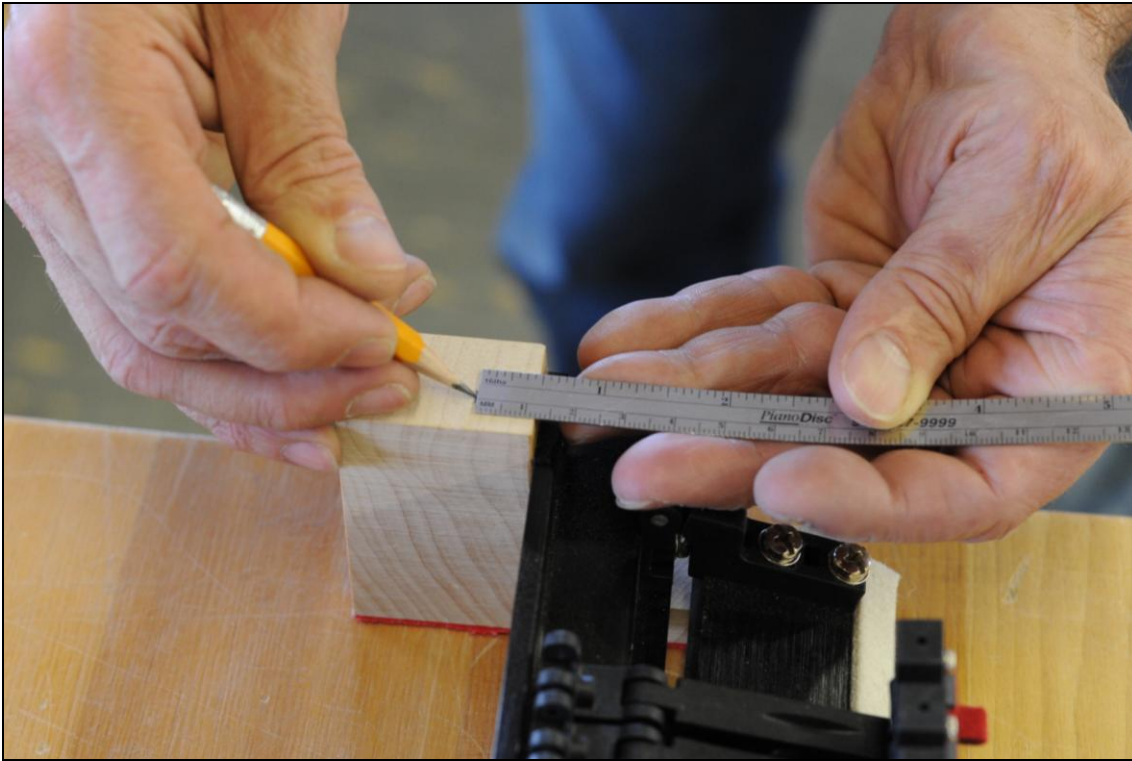

Measure back on the installation block from the rail surface the thickness of installation block as just established and place a mark on the block.

Repeat these procedures for the treble end of the damper action.

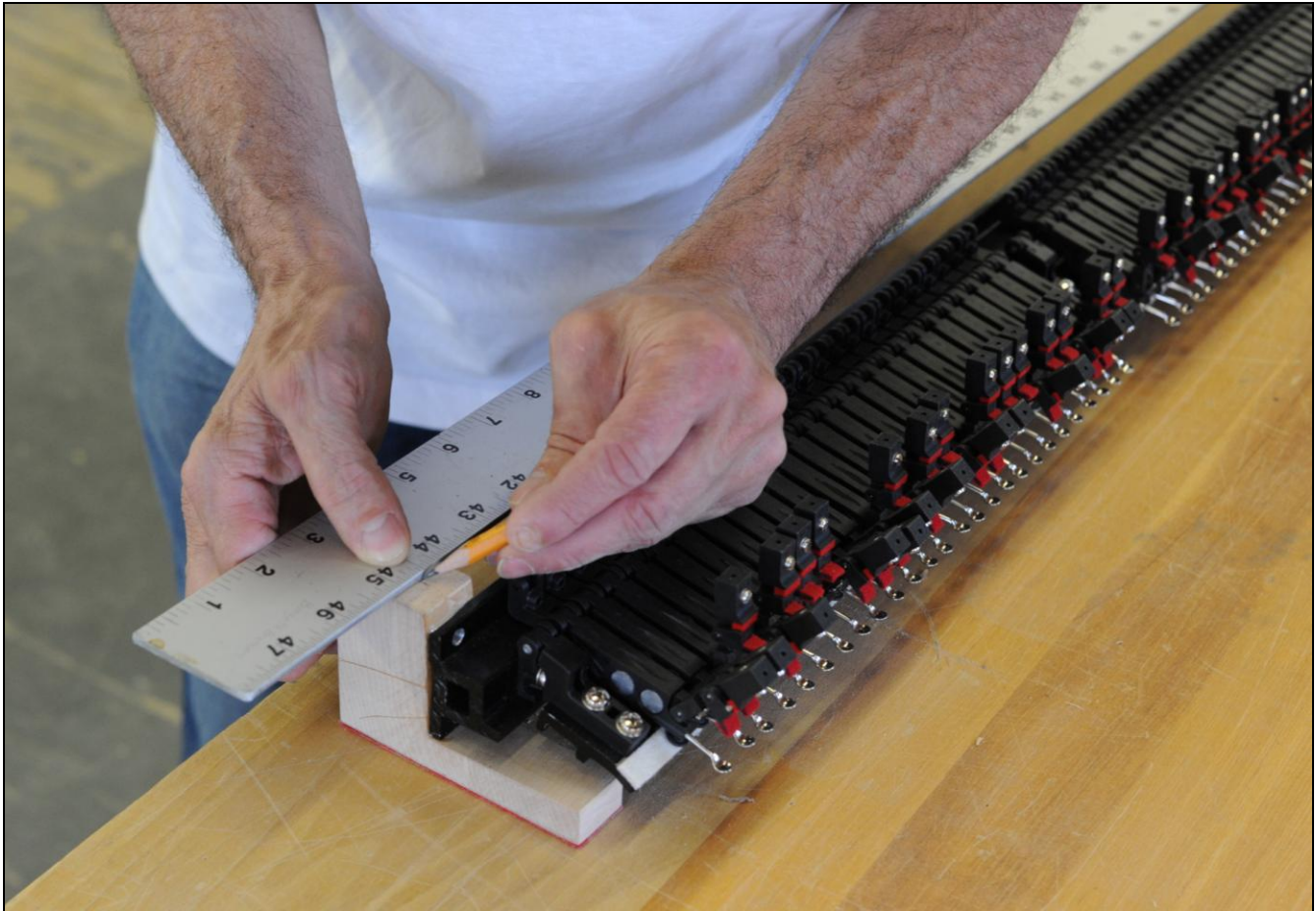

Use a straight edge to draw a line between the mark on the bass end and the mark on the treble end. Draw this line on all blocks glued to the damper flange rail.

It is entirely possible that the bass and treble ends will not be the same. If each end is not identical, then the line is drawn on a taper.

Do not use a square on each block if the line is tapered. If the taper is not cut into the blocks, they will contact the belly rail only on one side. When the mounting screws are tightened, it will place a rotational force on the blocks that will tend to bow the action rail.



On a band saw cut the back side of the line.

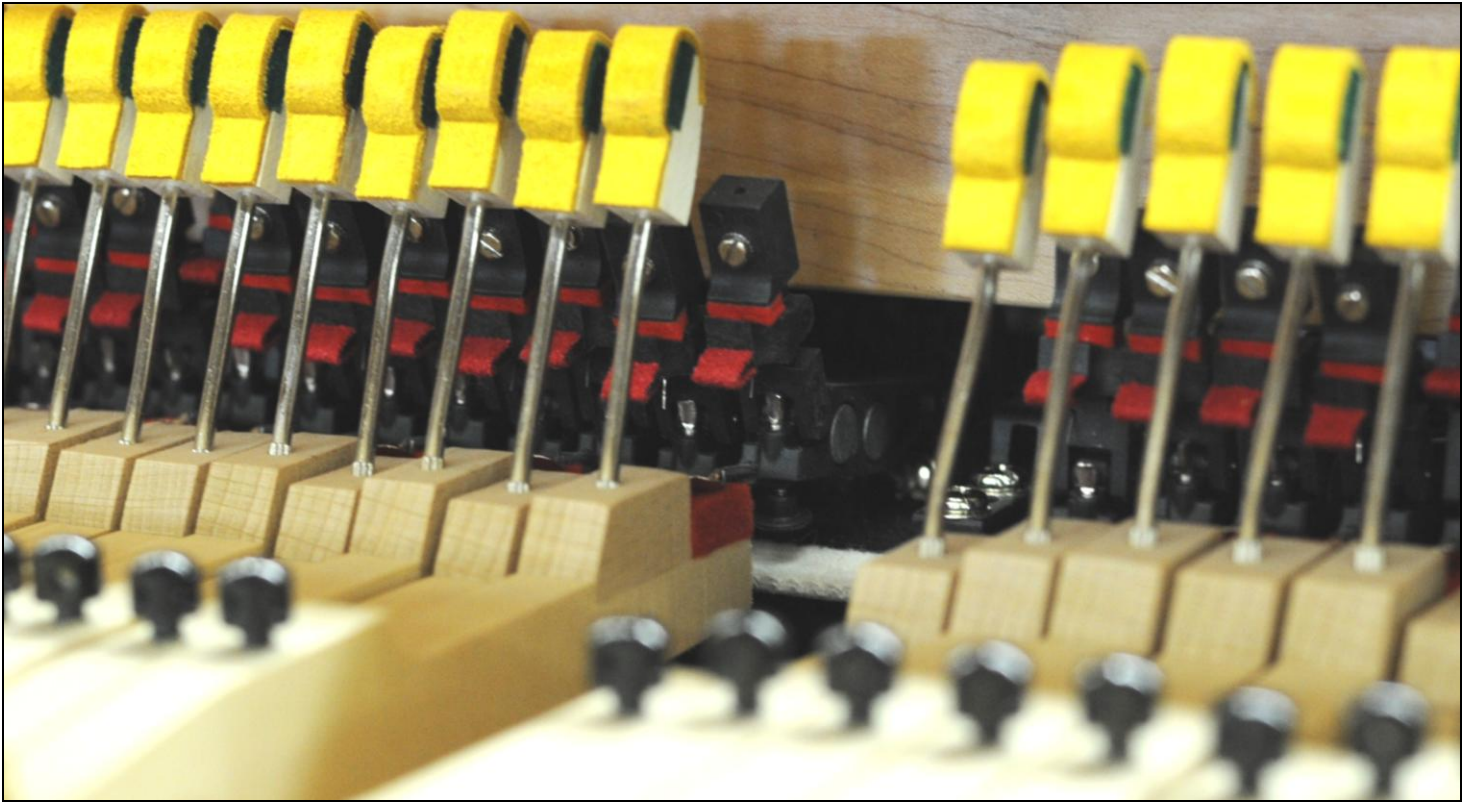

The damper action should be ready to install into the piano. Put the damper action into the damper cavity and check its fit.

Make sure that the installation blocks clear the hold down blocks for the keyboard. If necessary, move a hold down block or trim the installation block.

Use the spoon pickup point marked on the outside of the keys to determine if the front to back dimension is correct.

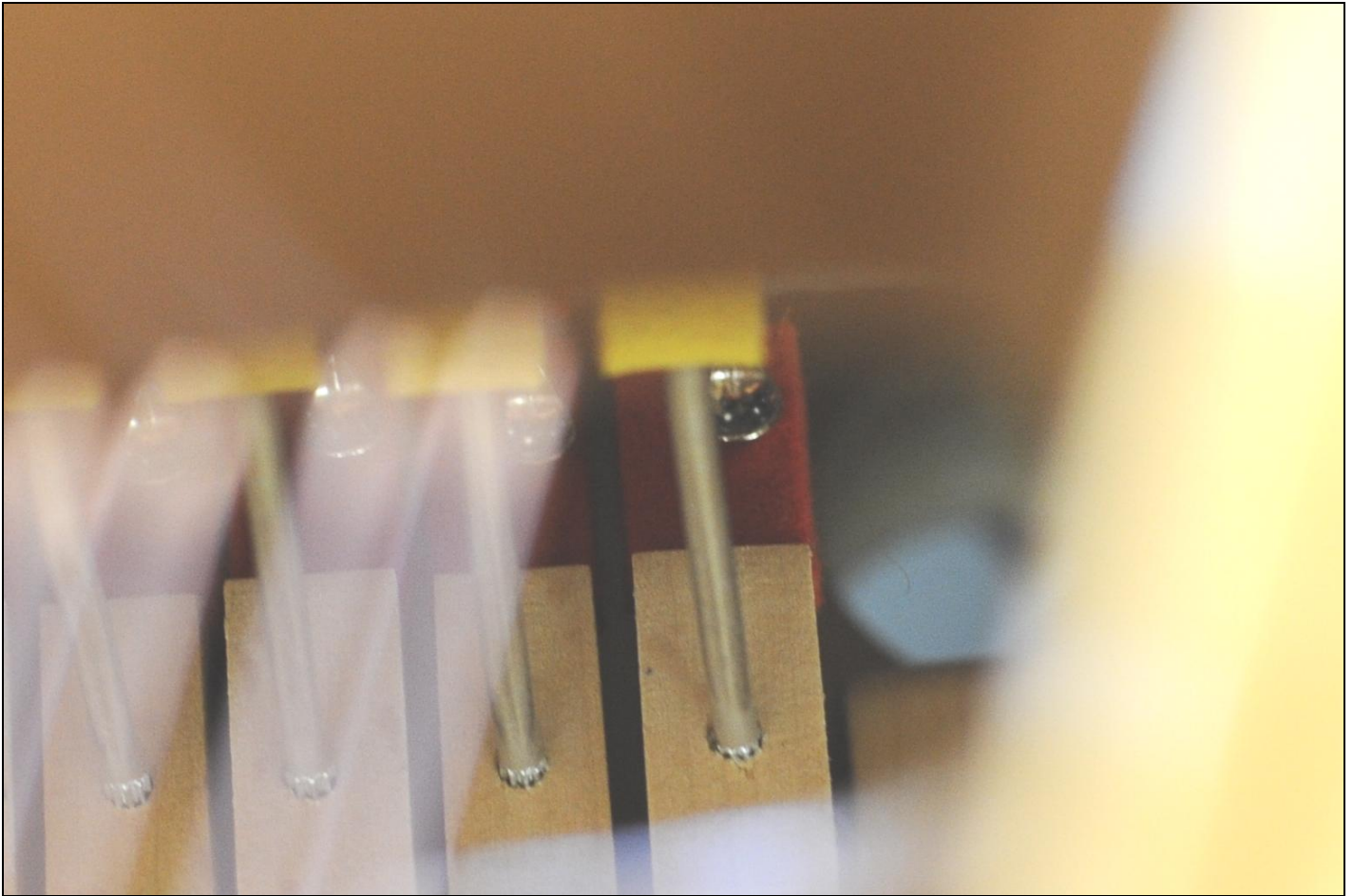

Move the damper action into the cavity, push it back against the belly rail and slide it side to side until the spoons are approximately 1.5mm or 1/16" from the treble side of the keys. Make sure that the center of the spoon is over the pickup point that you marked on the ends of the keys.

If it is not, add or remove material from one or the other or both of the installation blocks. Adjust the blocks until the damper action sits correctly in the cavity.

The picture shows the correct positioning for a piano that shifts towards the treble. If your piano shifts towards the bass then you will need to position the spoons to the opposite side of the key.

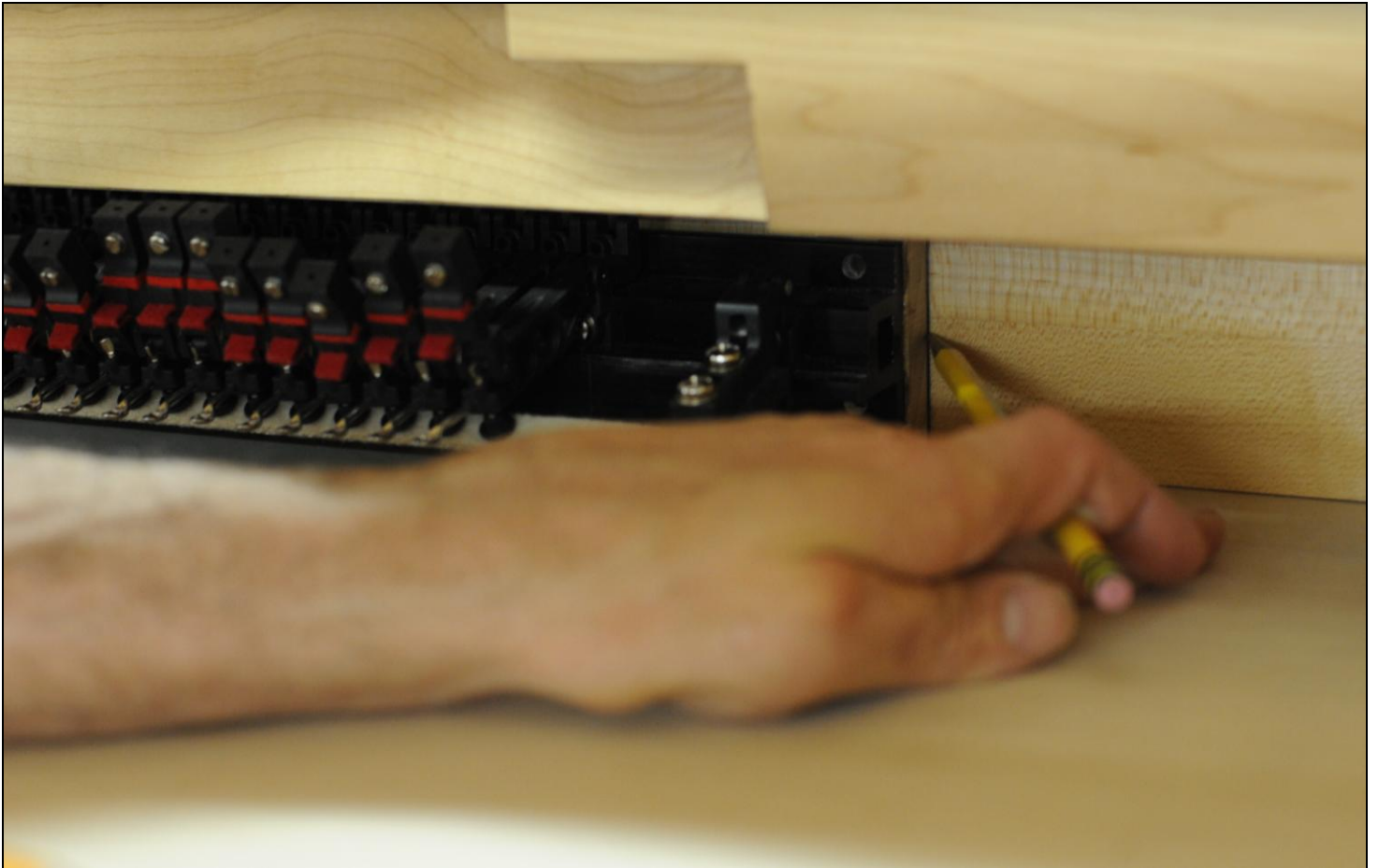

When the damper action is correctly positioned both front to back and side to side draw a line on the belly rail where the treble installation block meets the belly rail.

Now that the damper action is located properly, it is possible to locate the socket for the pitman.

Use tape on the front of the tray to mark the center line of the pitman.

Measure from the front of the tray to the center of the hole in the keybed. This tells you how far back the socket will need to be from the front of the tray.

Write the measurement down.

Remove the damper action from the piano.

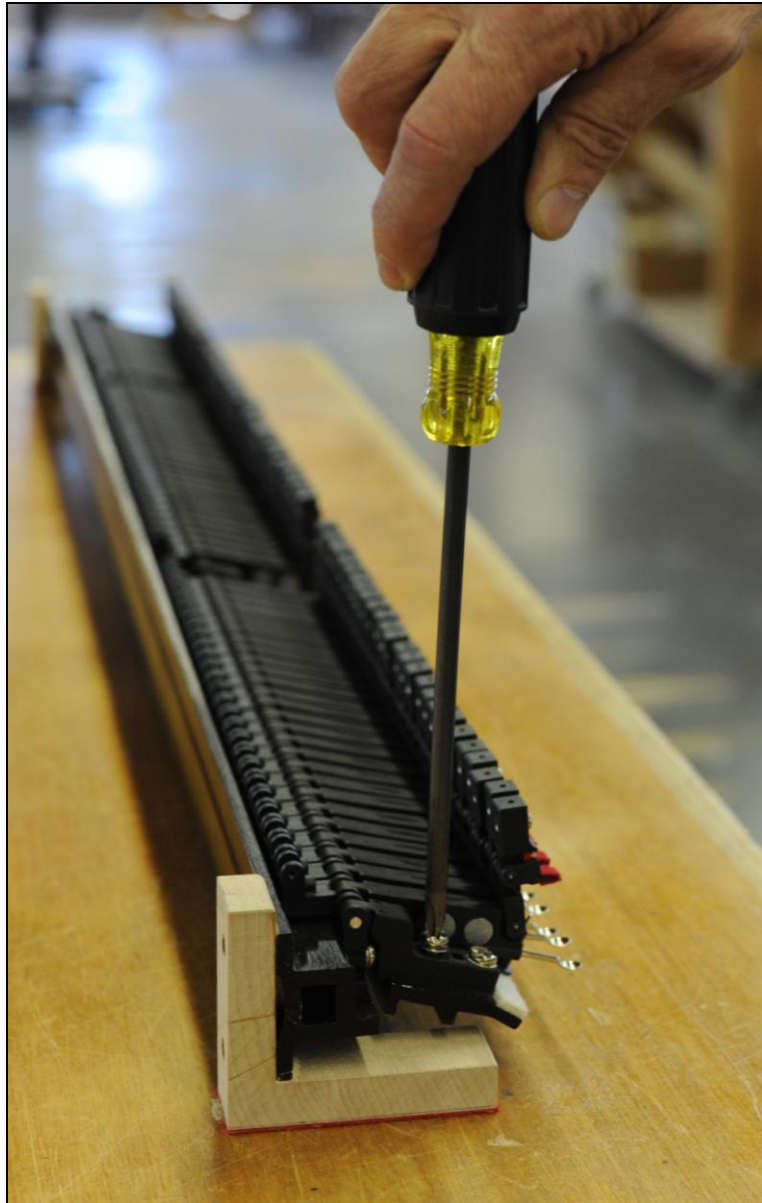

Remove the tray from the damper action. Remove the screws that fasten the tray flange to the tray itself. Set the tray aside while installing the damper action.

Install Pitman Block on Tray

Sustain Pitman Block Supplied with kit

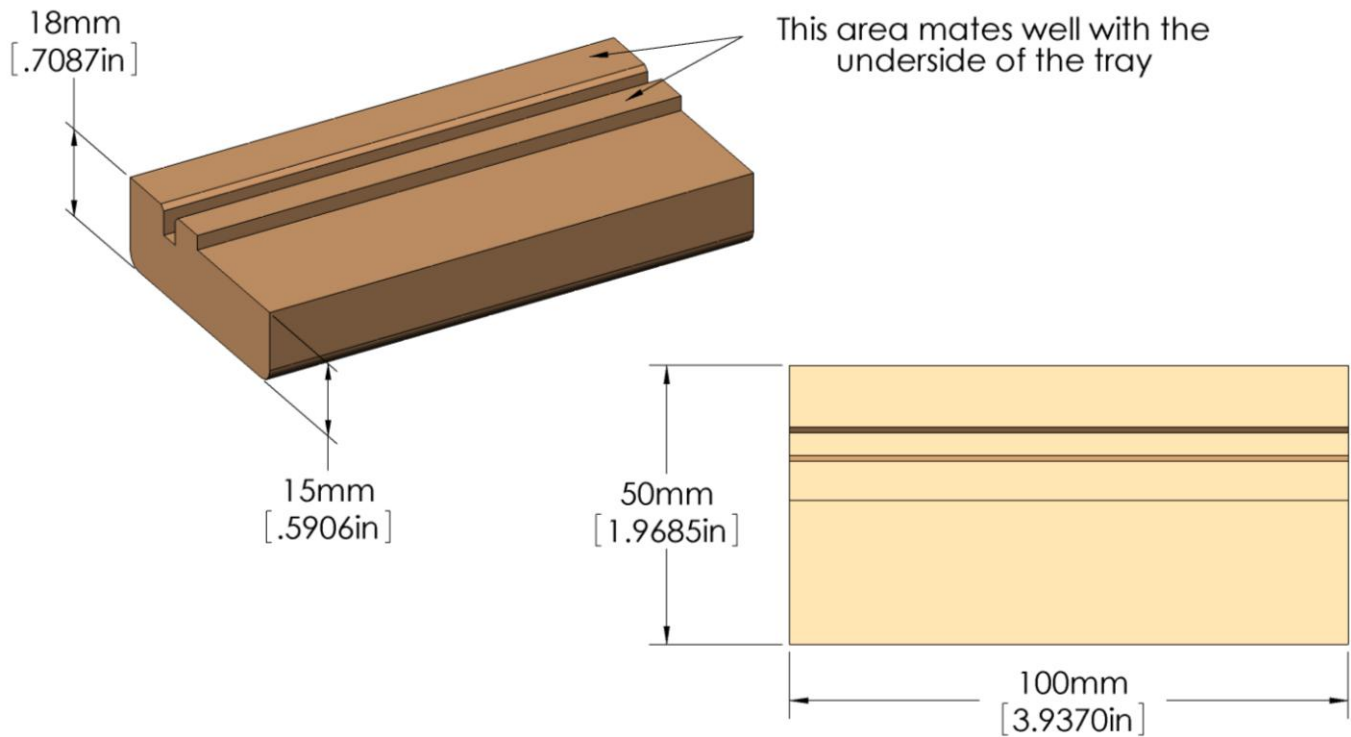

The pitman block is nothing more than a piece of maple cut to fit the bottom of the tray.

The part is designed to be oversized so you will be able to make it work in a variety of situations.

Sustain Pitman Block with Socket Drilled

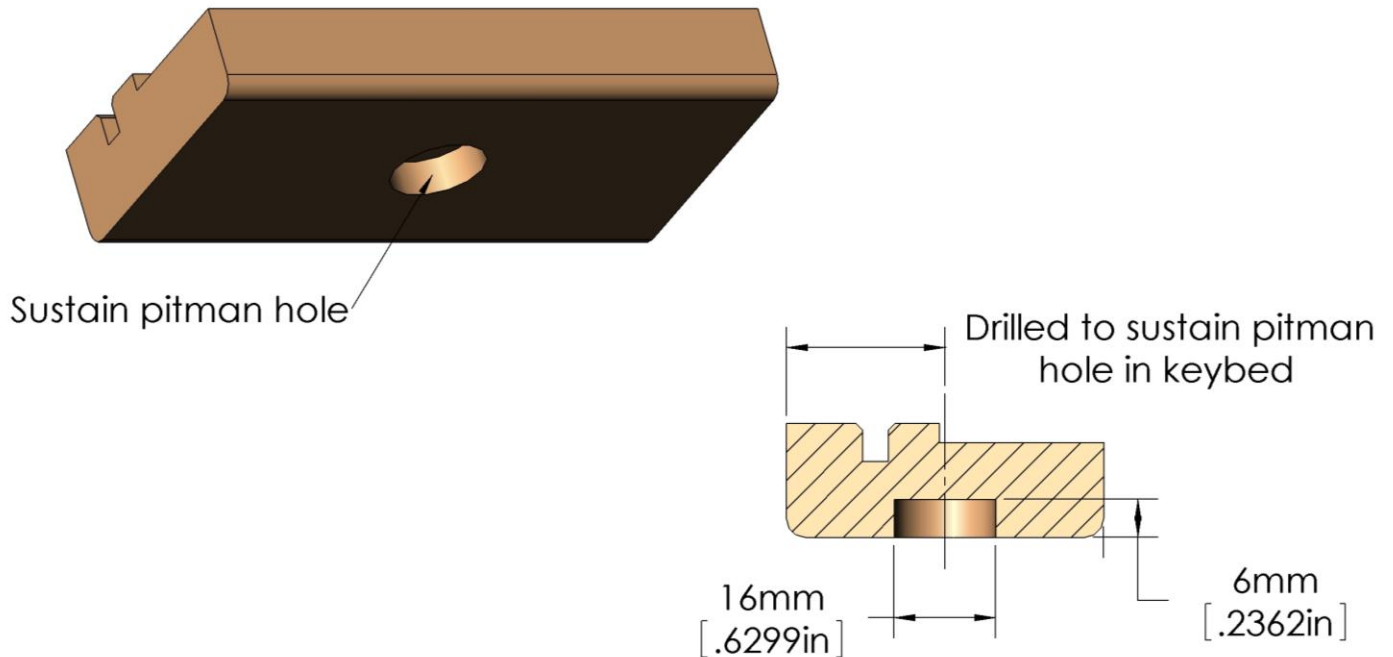

The best way to prevent sustain trap noise is for the pitman to sit into a socket in both the trap lever and the pitman block. Typically the hole in the keybed will be about 25mm (.984in) in diameter. This is large enough so the pitman never comes into contact with the keybed as it goes through its motion.

The socket is sized for a 13mm dowel with 16mm dense felt punching on both ends of the dowel. This way, the dowel is able to freely move with no sliding motion to cause creaks or groans.

To position the socket front to back mark the bottom of the pitman from the hole in the keybed.

Center the socket side to side.

Sustain Pitman Block Trimmed to Socket

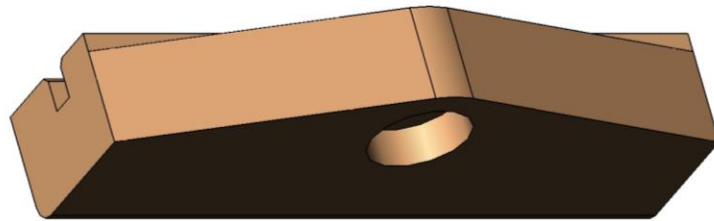
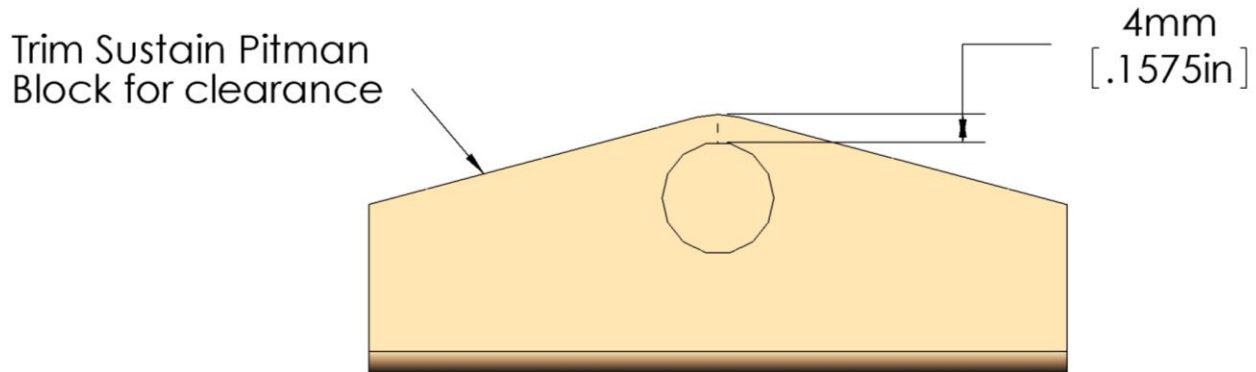

The pitman block was designed to be oversized. This allows it to work in many circumstances. As a practical matter, that means that the block as shipped is nearly always too large until trimmed.

After the socket is drilled, trim the pitman block as in the above drawing. This will make the pitman block not hit the ends of the keys when operated.

Sustain Pitman Drilling Dimensions on Tray

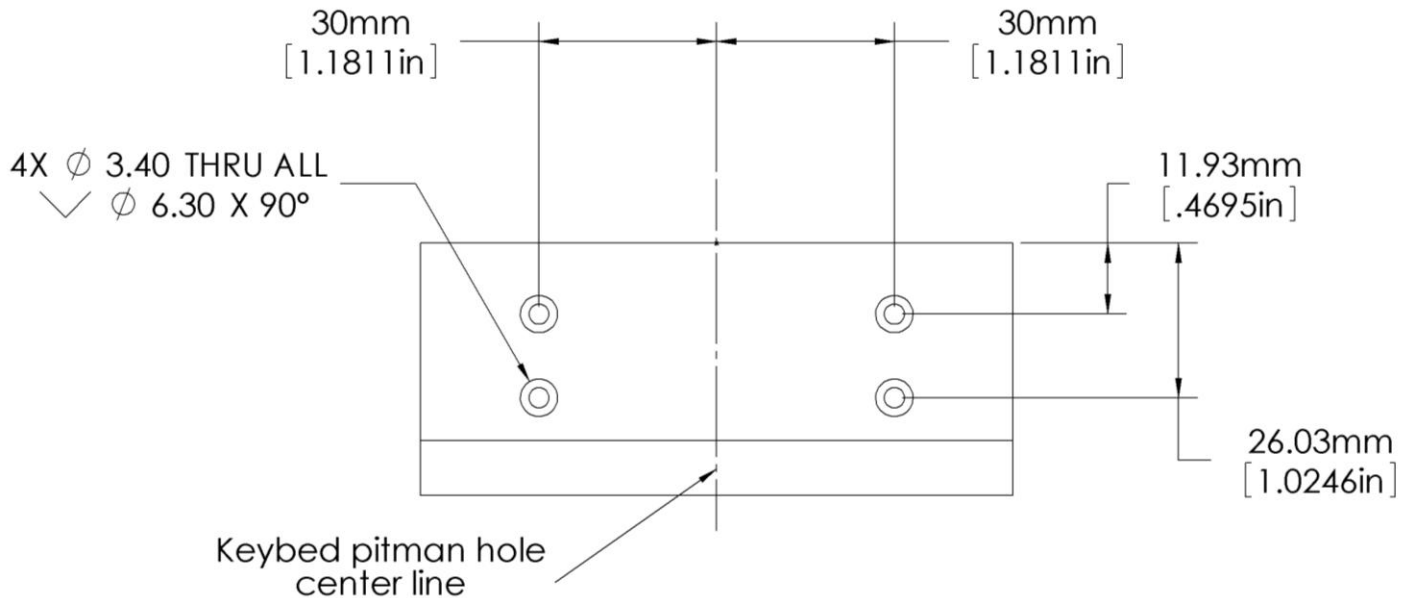

From the top, drill and countersink four mounting holes in the tray. See drilling dimensions and sizes above.

All drilling locations come from the line you marked on the tray in relation to the pitman hole in the keybed.

Lay tape down on the tray to draw on. From the pitman line on the tray draw a centerline. Measure 30mm (1.181in) in each direction for the horizontal location of the pitman block screw holes.

Measure, as shown above 11.93mm (.47in), for the back row of holes.

Measure as shown above 26.03mm (1.025in) for the front row of holes.

Countersink the holes to 6.3mm (.248in).

Drill 2mm (.079in) holes through and countersink the holes for a 3mm (.118in) self tapping Phillips flat head screw.

Sustain Pitman Block Mounted to Tray

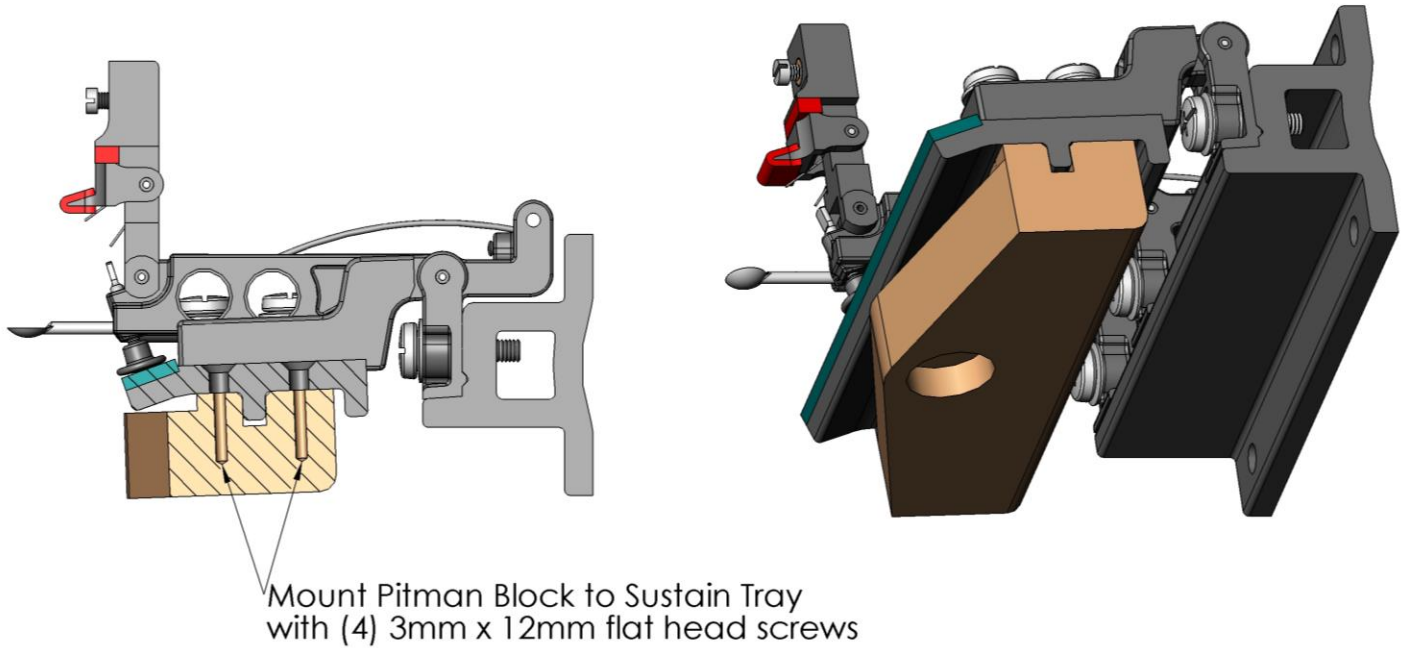

Position the pitman block under tray so the centerline on the socket corresponds to the mark you put on the tray previously.

Drill through the tray into the maple pitman block with a pilot drill bit with a 2mm (.079in) diameter.

Mount the pitman block that has been drilled for a socket and trimmed with four 3mm x 20mm self tapping Phillips flat head screws.

Install Damper Action in Piano

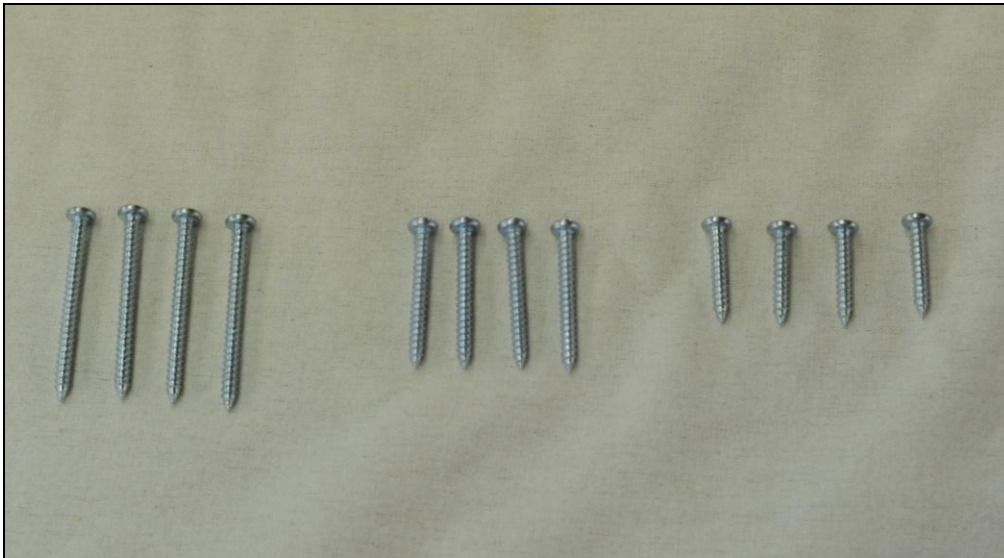

The kit of mounting screws consists of the correct number of 3.9mm self tapping pan head screws for the rail supplied in the kit. Because, WNG cannot possibly know the correct length you will need, we supply the screws in three different lengths. For example, for a thick rail, WNG supplies four screws in three lengths for a total of 12 screws. For a thin rail, WNG supplies five screws in three lengths for a total of 15 screws. For both rails the lengths are 30mm, 40mm and 50mm.

The lengths chosen should cover the vast majority of situations.

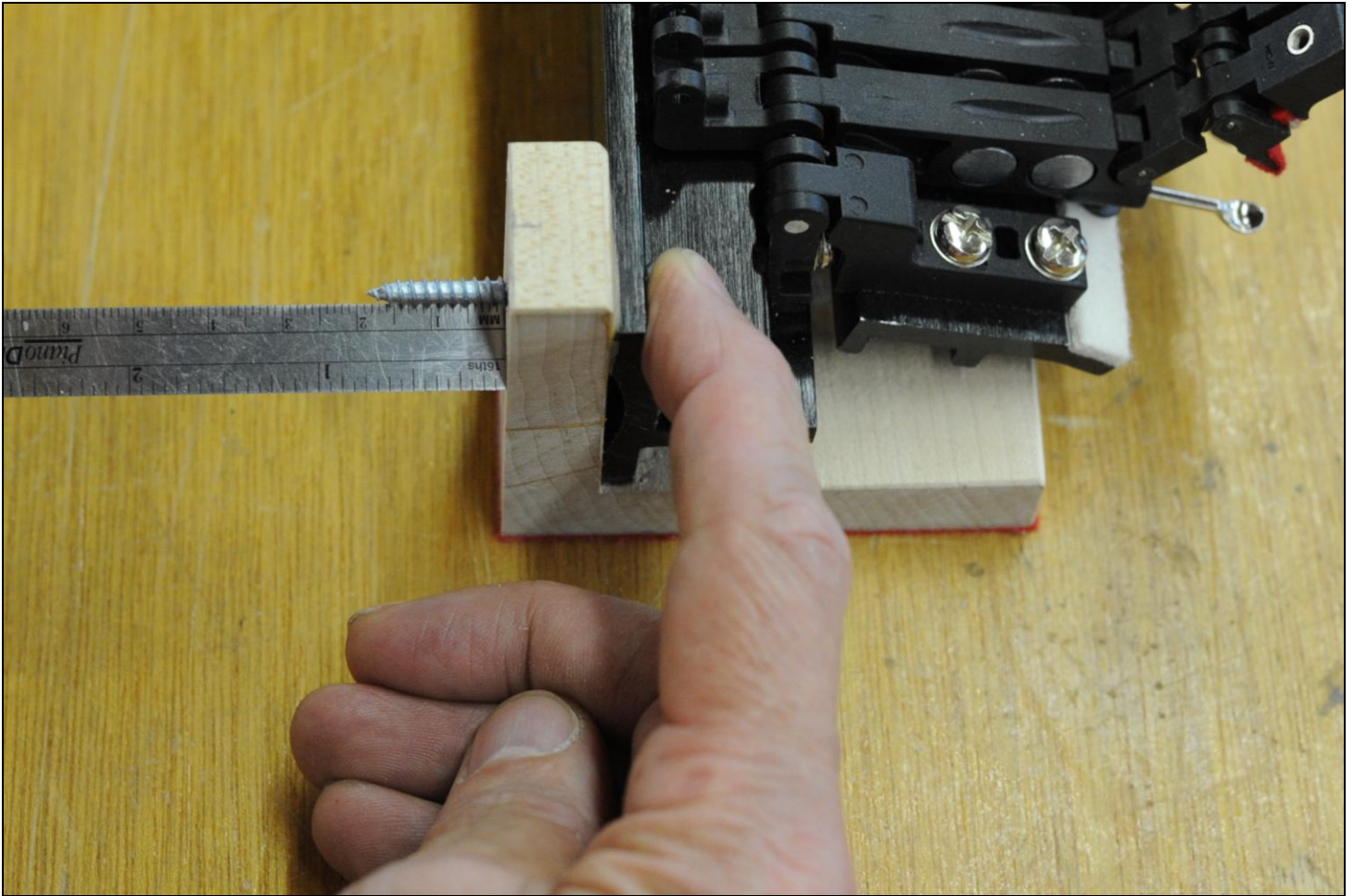

It is not good workmanship to either drill through or run a screw out the other side of the belly rail.

It is hard to know the exact thickness of the belly rail. The belly rail could be as thin as 19mm or $\frac{3}{4}$ " thick. For this reason, WNG strongly recommends you limit the length the screws past the installation block to 16mm or about $\frac{5}{8}$ ".

Of course, if you are sure there is sufficient material, you can use any screw you wish.

Put a screw through the rail and the installation block and measure the distance it protrudes. Use a ruler either metric or English as you please.

Try several screws. If you cannot get the correct length use a bench grinder to shorten the screws to a workable length.

The length of the screw could well be different on each end. On the thin rail, the length could be different on each screw.

If all the screws are too short or too long, then you will need to purchase screws of the correct length to complete the job.

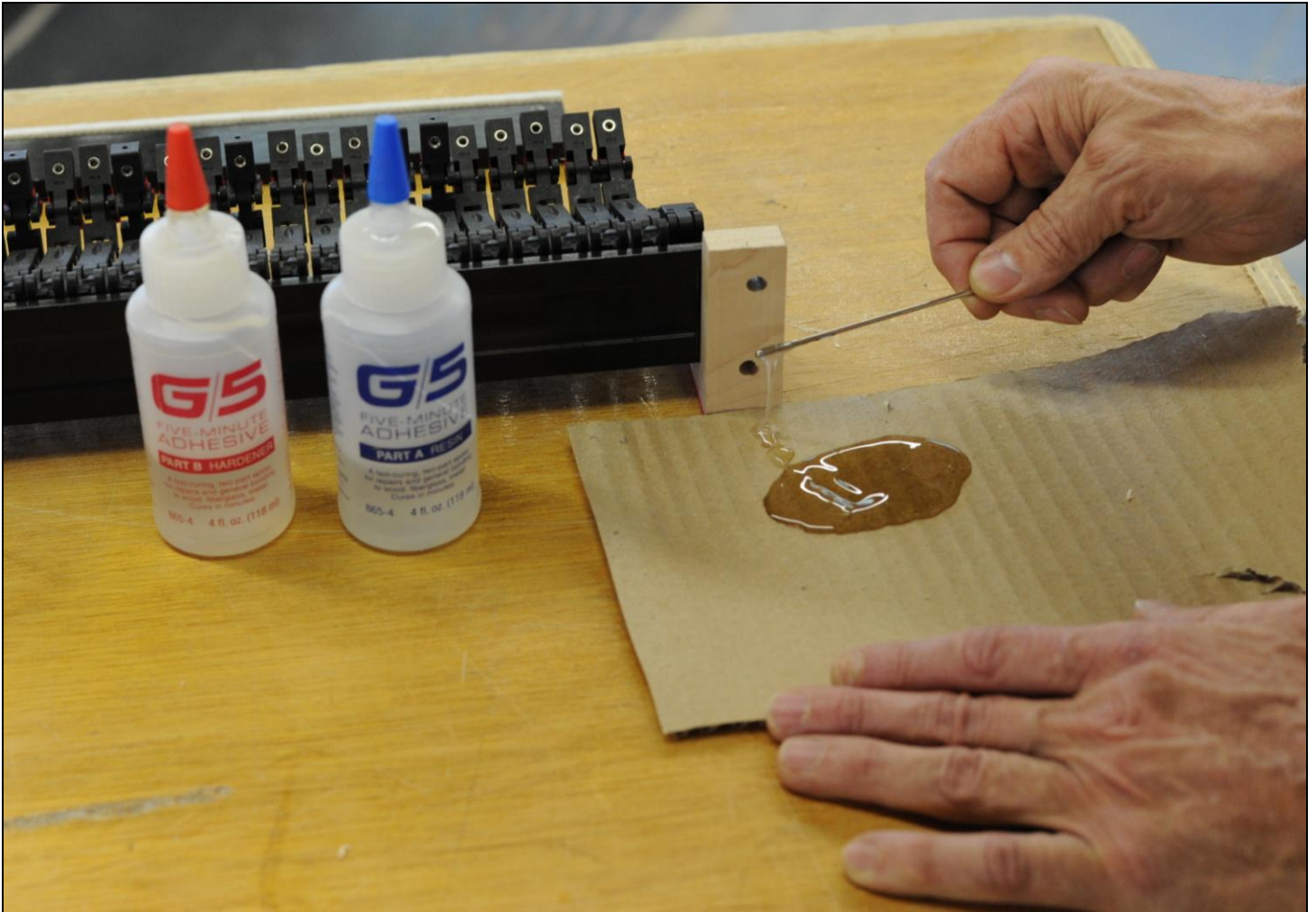

Apply a thin coat of 5 min epoxy to the belly rail side of the installation blocks.

Move the damper action into place and press the blocks against the belly rail. Use the line you drew on the belly rail to position the belly rail side to side.

Allow the glue to harden.



After the glue has hardened, drill for the mounting screws.

Use a 3mm or 1/8" drill bit to drill for the screws. It is best to use aircraft length drill bits (about 6" or 150mm long).

Drill the pilot holes for the screws in the belly rail through the screw holes in the rail. Mark the drill bit with tape so you do not drill through the belly rail.



Install the screws that make permanent the mounting of the damper action to the belly rail. If the screws have several lengths make sure to use the correct length in each hole.

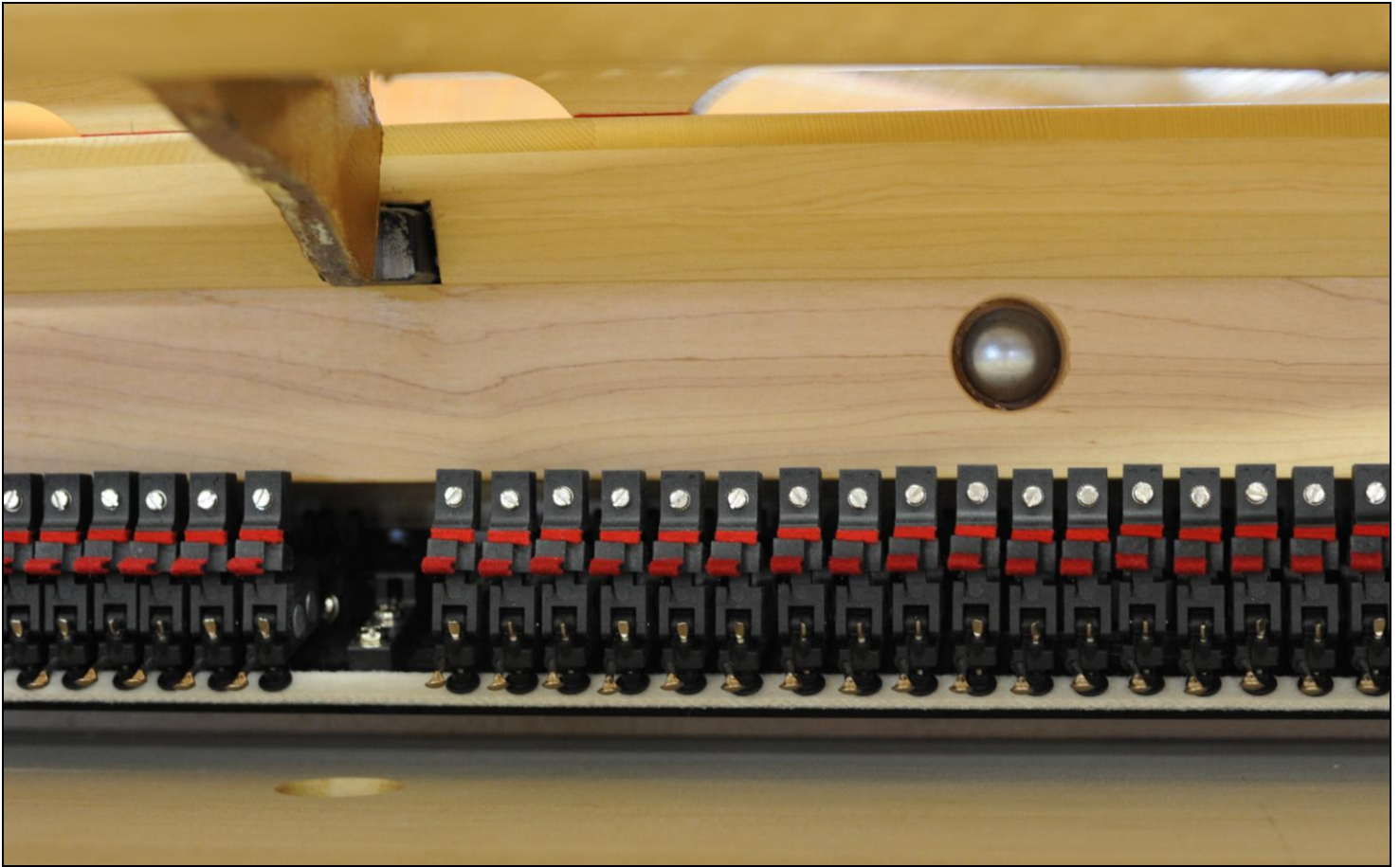

Re-install the tray with the sustain pitman block in place.

The installation is done. You are now ready to install dampers.

WNG strongly recommends that you install new damper wires in either the old or new damper heads when you replace a damper action.